

CombiNorm-Control



The compact terminal enclosure

The CombiNorm-Control was designed to hold double-pole PCB connection terminals, and two of its advantages are its compactness and versatility.

The CombiNorm-Control enclosure is supplied in three widths and, depending on the design, can hold up to 16 double-pole terminals. Terminal sockets which are not required can be closed by the use of covers.

Accessories include light guides and adjustment axles for coding switches.

Enclosure material: polycarbonate.

Enclosure colour: light grey, similar to RAL 7035.

Ingress protection: IP 20.

CNC 17

Order designation

Model	Order no.	Description	Width	PU
CNC 17	65500117	Enclosure for max. 4 x double-pole terminals	17.5 mm	10 pieces

Scope of delivery:

Basic enclosure, front panel, latch

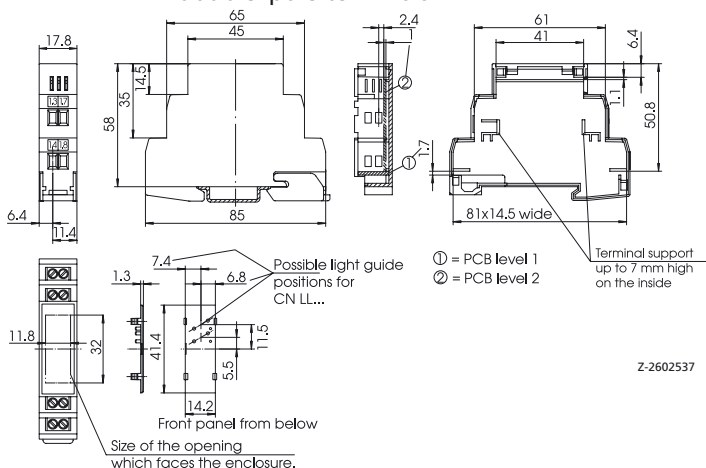

CNC 35

Order designation

Model	Order no.	Description	Width	PU
CNC 35	65500135	Enclosure for max. 8 x double-pole terminals	35 mm	10 pieces

Scope of delivery:

Basic enclosure, front panel, latch (fitted), enclosure screw

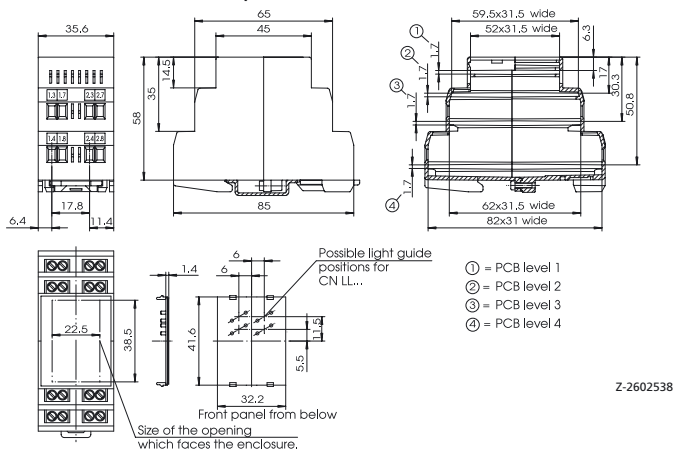

CNC 70

Order designation

Model	Order no.	Description	Width	PU
CNC 70	65500170	Enclosure for max. 16 x double-pole terminals	70 mm	5 pieces

Scope of delivery:

Basic enclosure, front panel, latch (fitted), enclosure screw

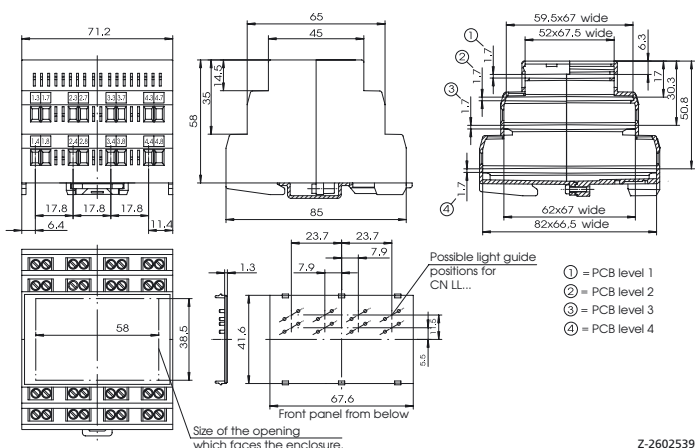

Terminal enclosure for latching onto DIN rail 35 mm acc. to DIN EN 60715 TH35.

The basic enclosure consists of two half-shells. With CNC 17, the two enclosure halves are latched together. With sizes CNC 35 and CNC 70, the halves are hooked into the upper section and secured from underneath with a screw. The front panels can be latched on subsequently.

On the inside of the front panels, the pins onto which the light guides are fitted are moulded on. (The front panel drawing shows the various positions for the light guides). The PCBs can be fitted horizontally or vertically in the enclosure. Two types of terminals are available in order to ensure optimal use of the PCB.

CombiNorm-Control

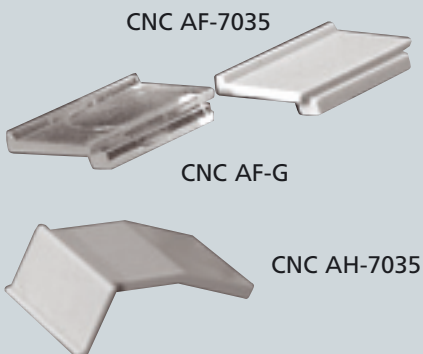

The covers can be used to seal the unused terminal sockets fully or only partially.

Covers

Order designation

Model	Order no.	Description	PU
CNC AF-7035	65501035	Flat cover RAL 7035	50 pieces
CNC AH-7035	65502035	High cover RAL 7035	50 pieces
CNC AF-G	65501000	Flat cover, clear	50 pieces
CNC AH-G	65502000	High cover, clear	50 pieces

Note:

CNC AF = cover for the upper terminal area of a double-pole terminal (cable entries can be used for additional ventilation).
 CNC AH = cover for the complete terminal area of a double-pole terminal.
 The covers are fitted to the free terminal sockets from the outside.

Light guides

Order designation

Model	Order no.	Description	PU
CNC LL-03	65503003	Light guide 2.8 mm	50 pieces
CNC LL-28	65503028	Light guide 28.4 mm	50 pieces
CNC LL-49	65503049	Light guide 48.6 mm	50 pieces
CNC LL-KW	65503010	Light guide (short) 90°	50 pieces
CNC LL-LW	65503020	Light guide (long) 90°	50 pieces
CNC LLS-7035	65503030	Light guide plug 2.8 mm; RAL 7035	50 pieces



The light guides match the relevant PCB levels. Plugs (CNC LLS-7035) can be used for different unit configurations with the same front panel so that unused openings in the front panel can be closed off.

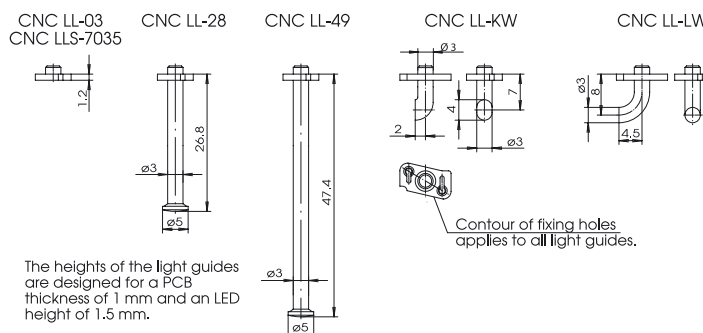

Z-2602541

Adjustment axes for coding switches

Order designation

Model	Order no.	Description	PU
CNC SA 17	65504017	Adjustment axis 17.5 mm	50 pieces
CNC SA 31	65504031	Adjustment axis 31 mm	50 pieces
CNC SA 51	65504051	Adjustment axis 51.4 mm	50 pieces

Note:
 Suitable potentiometer: PT 6 (Piher) (potentiometer, log. & lin., upright and horizontal)

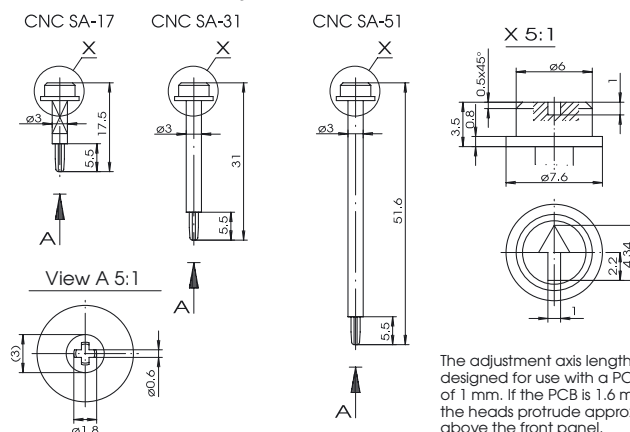

Z-2602542



The adjustment axes are designed for coding switches PT 6 (Piher) and to match the PCB levels.

Connection terminals

Order designation

Model	Order no.	Description	PU
AK 8191/2	66000092	Double-pole, upright, PCB horizontal	1 piece
AK 8191/2DL	66000052	Double-pole, fitted on left (looking at component side), PCB upright	1 piece
AK 8191/2DR	66000062	Double-pole, fitted on right (looking at component side), PCB upright	1 piece

AK 8191/2 DL

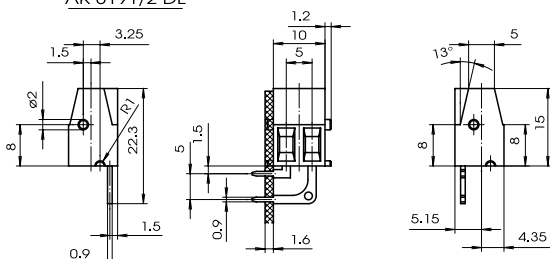

AK 8191/2

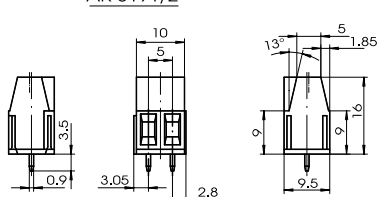

AK 8191/2 DR

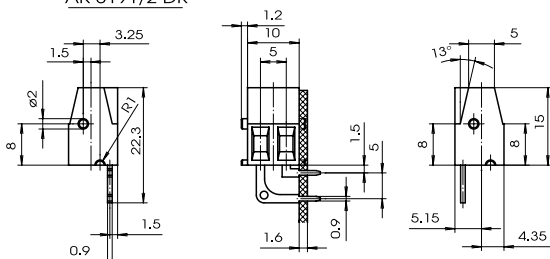

drill hole diagram

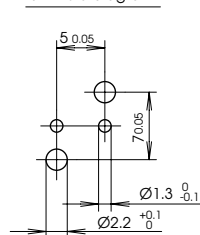

Z-2601536

Z-2602543

PCB dimensions for CNC 17, 35 and 70

PCBs for CNC 17

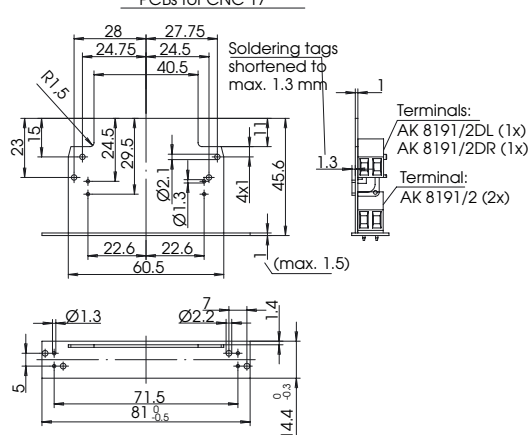

PCBs for CNC 35 / 70

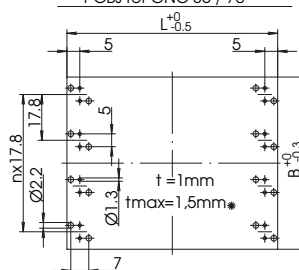

Suitable terminals: AK 8191/2

CNC 35	L-0.5	B-0.3	t	n
PCB level 1	42.0	31.5	max.1.5	Fitting with terminals
PCB level 2	59.5	31.5	max.1.5*	is not possible
PCB level 3	62.0	31.5	max.1	1
PCB level 4	82.0	31.0	max.1	1

CNC 70	L-0.5	B-0.3	t	n
PCB level 1	42.0	67.5	max.1.5	Fitting with terminals
PCB level 2	59.5	67.5	max.1.5*	is not possible
PCB level 3	62.0	67.0	max.1	3
PCB level 4	82.0	66.5	max.1	3

Important:

Components must not be fitted in the area of the PCB guide slots or the enclosure latch unit. For further details, please see the catalogue drawings in respect of the relevant enclosures.

* Not suitable for use with light guides (CNC LL-...). If the adjustment axes are used, the heads protrude over the front panel by approx. 0.7 mm.



Dimensions:
Grid dimension 5 mm
Drill hole Ø 1.3 mm
Insulation stripping length 6.5 mm

Colour: green, similar to RAL 6018

Material:
Insulation material PA
Flammability class UL94-V-0
Contact bow tin-plated with electrical grade copper
Solder pins tin-plated with electrical grade copper

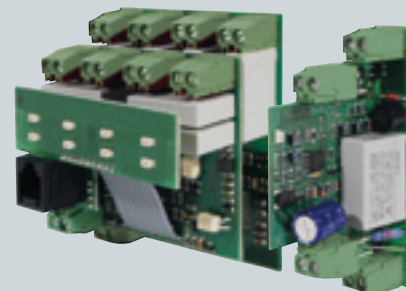

Z-2602545