



The advantage of using the Element enclosure system for your electronic products is that components can be fitted quickly and easily through the side-opening of the base.

This makes it easy to access your electronic components for servicing purposes. Enclosures with air vents E....L are available to ensure optimal heat dissipation. In addition, front membranes and membrane keypads using your special layout are available in the lid surface (1 mm recess) of enclosure types E....F.

Mounting bosses for self-tapping screws are provided in the base for fitting components, PCBs or mounting plates.

The break-out keyholes in the base allow fast fitting to wall or machine surfaces (not E 406/E408).

Wall brackets are also included in the list of accessories.

**Enclosure material:** Impact-resistant polystyrene; for technical data see pages 646-650.

**Colour:** Lid light grey, similar to RAL 7035; base graphite grey, similar to RAL 7024; special colours on request.

**Ingress protection:** Closed: IP 40/DIN EN 60529; with air vents: IP 30/DIN EN 60529.

**Scope of delivery:** Lid and base, 4 fixing screws (E 434 S without screws – with moulded-on snap lock). E 430 A: incl. aluminium panel in lid.

**Accessories (additional charge):**

E-WL: Wall brackets (1 set = 4 pieces)  
 E-SV: Snap lock (1 set = 4 pieces)  
 E-M...: Mounting plate  
 E-DO...: Lid fixing set at top, 4 screws including inserts for base  
 E-HG: Handle  
 E-F: Rubber feet (1 set = 4 pieces)

**Note:**

F-version lids have a recessed space for flush mounting of membrane keypads.

Enclosures		External dimensions		
Model	Order no.	L	W	H
E 406	05406000	65	50	30
E 406 F*	05406700	65	50	31
E 406 VL	05406900	65	50	30
E 408	05408000	65	50	45
E 410	05410002	100	50	25
E 410 F*	05410700	100	50	26
E 410 FVL*	05410800	100	50	26
E 420	05420002	100	50	40
E 420 F*	05420700	100	50	41
E 420 FVL*	05420800	100	50	41
E 430	05430002	120	65	40
E 430 A*	05430500	120	65	40
E 430 F*	05430700	120	65	41
E 430 FVL*	05430800	120	65	41
E 434 S	05434000	188	110	40
E 435	05435000	120	65	65
E 440	05440002	150	80	55
E 440 F*	05440700	150	80	56
E 440 FVL*	05440800	150	80	56
E 440 VL	05440200	150	80	55
E 445	05445000	150	80	80
E 450	05450002	188	110	70
E 450 F*	05450700	188	110	71
E 450 FVL*	05450800	188	110	71
E 450 VL	05450200	188	110	70
E 460	05460000	188	110	100
E 470	05470000	188	110	120

F = with membrane area for membrane keypads or front membranes

VL = with vertically moulded-in air vents

FVL = with membrane area for membrane keypads or front membranes and with vertically moulded-in air vents

A = with aluminium front panel in lid

S = with snap lock

\* available on request



# Element

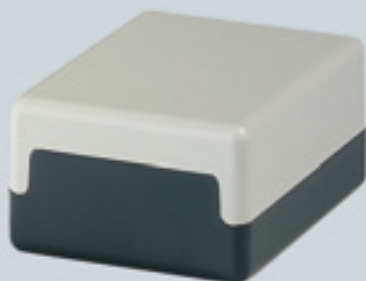

E 406

## Element enclosures E 406 (F VL) / E 408

Order designation		Ext. dimensions		
Model	Order no.	L	W	H
E 406	05406000	65	50	30
E 406 F*	05406700	65	50	31
E 406 VL	05406900	65	50	30
E 408	05408000	65	50	45**

F = with membrane area  
 VL = with vertically moulded-in air vents

\* available on request  
 \*\* other dimensions similar to E 406

Version E 406 F

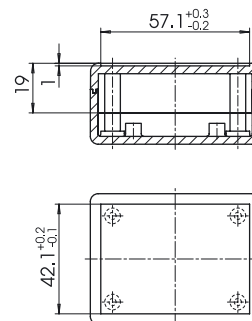

Version E 406 VL

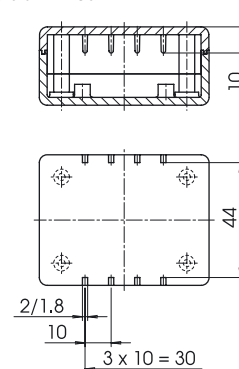

## Element enclosures E 410 (F VL)

Order designation		Ext. dimensions		
Model	Order no.	L	W	H
E 410	05410002	100	50	25
E 410 F*	05410700	100	50	26
E 410 FVL*	05410800	100	50	26

F = with membrane area  
 F VL = with membrane area and with vertically moulded-in air vents

\* available on request

Version E 410 F

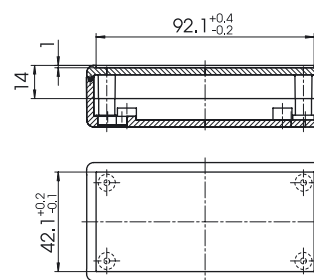

Version E 410 FVL

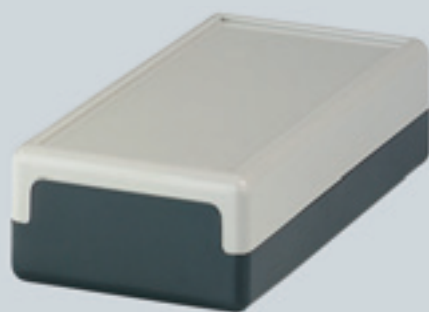
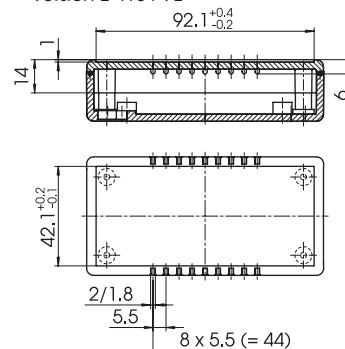

E 410 F

**View into the base (E 406)**

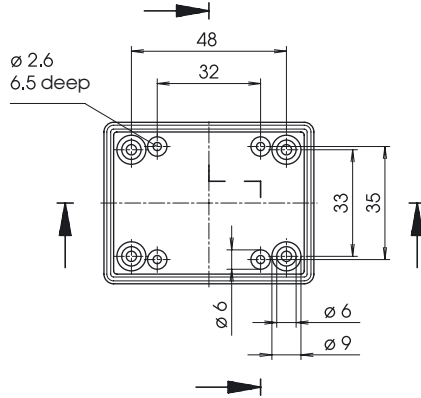

**View into the lid (E 406)**

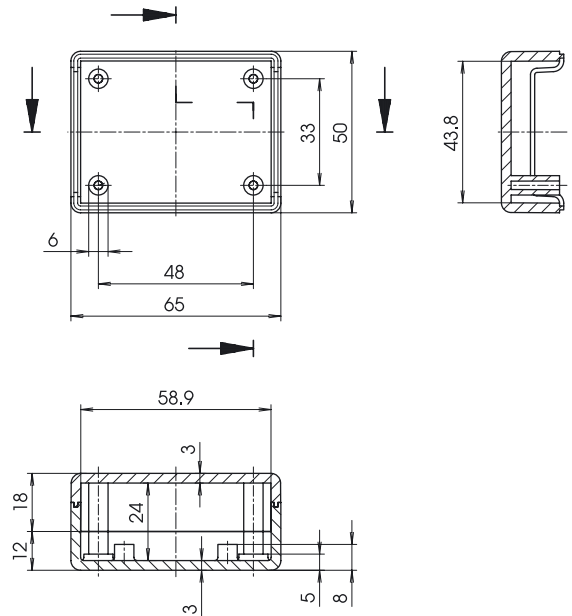

**E 406  
E 408**

Z-2801669

**View into the base**

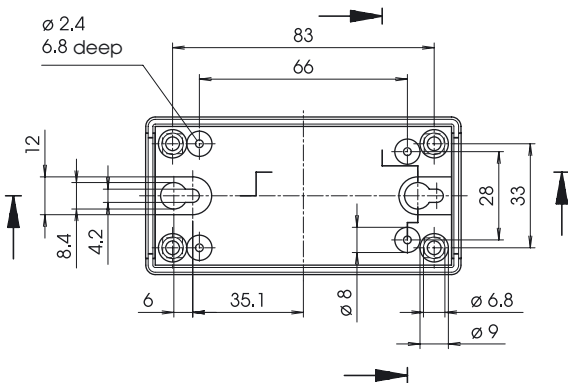

**View into the lid**

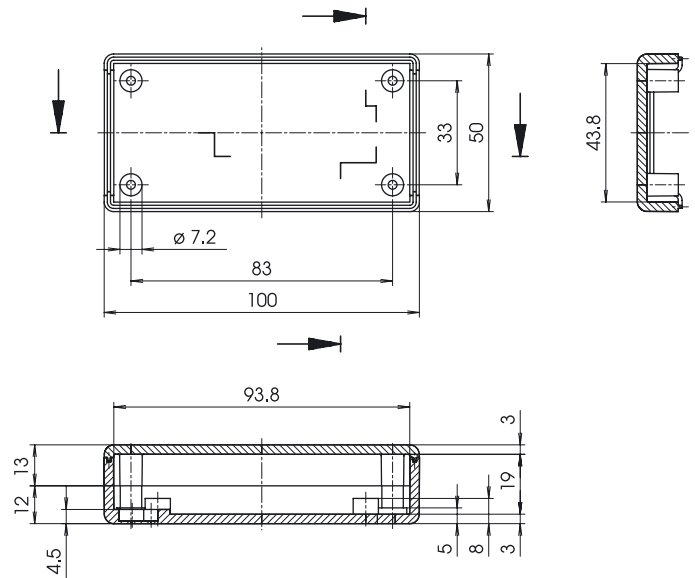

**E 410**

Z-2801042

# Element



E 420

## Element enclosures E 420 (F VL)

Order designation		Ext. dimensions		
Model	Order no.	L	W	H
E 420	05420002	100	50	40
E 420 F*	05420700	100	50	41
E 420 FVL*	05420800	100	50	41

F = with membrane area  
 F VL = with membrane area and with vertically moulded-in air vents

\* available on request

Version E 420 F

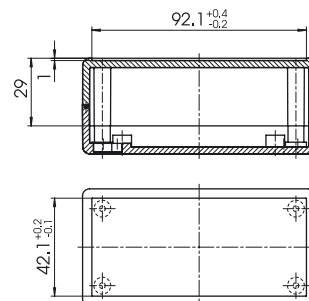

Version E 420 FVL

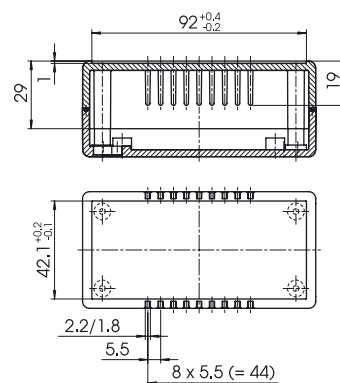

## Element enclosures E 430 / 435

Order designation		Ext. dimensions		
Model	Order no.	L	W	H
E 430	05430002	120	65	40
E 430 F*	05430700	120	65	40
E 430 FVL*	05430800	120	65	40
E 430 A*	05430500	120	65	40**
E 435*	05435000	120	65	65**

F = with membrane area  
 F VL = with membrane area and with vertically moulded-in air vents  
 A = with aluminium front panel

\* available on request  
 \*\* other dimensions similar to E 430  
 • lid with threaded insert for screwing base

Version E 430 F

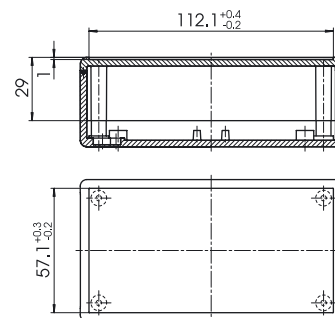

Version E 430 FVL

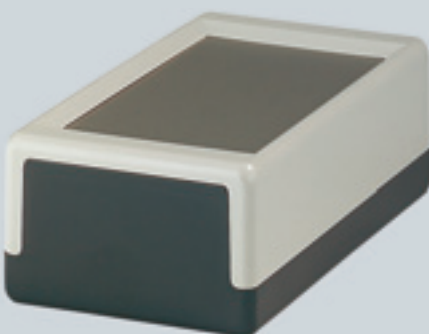
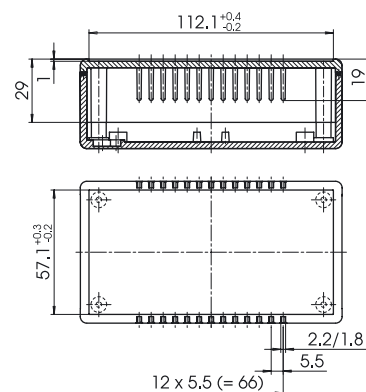

E 430 A

**View into the base**

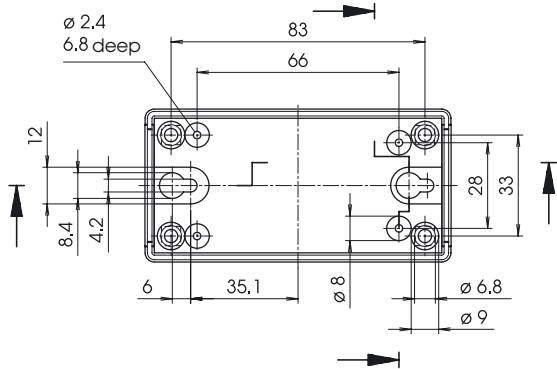

**View into the lid**

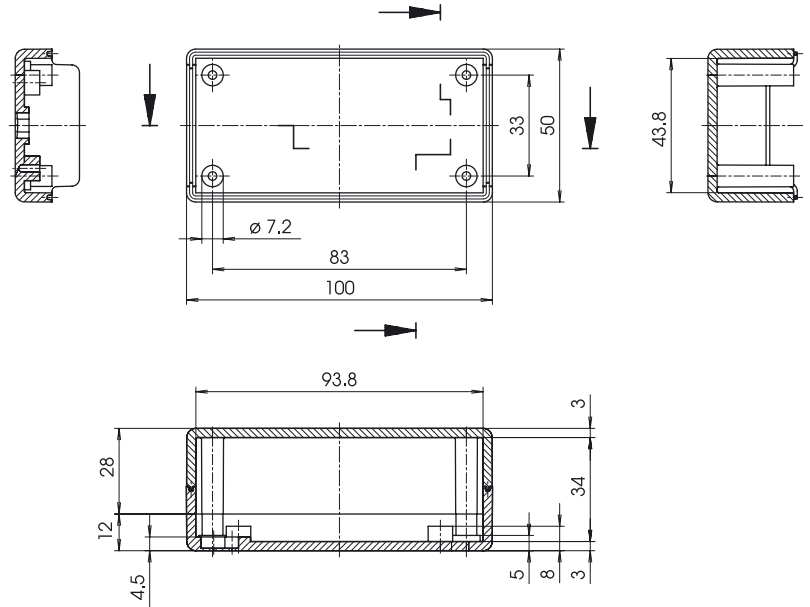

**E 420**

Z-2801043

**View into the base (E 430)**

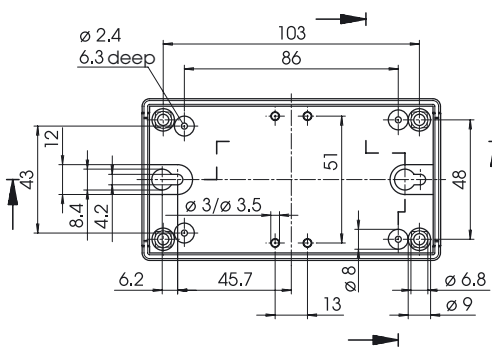

**View into the lid (E 430)**

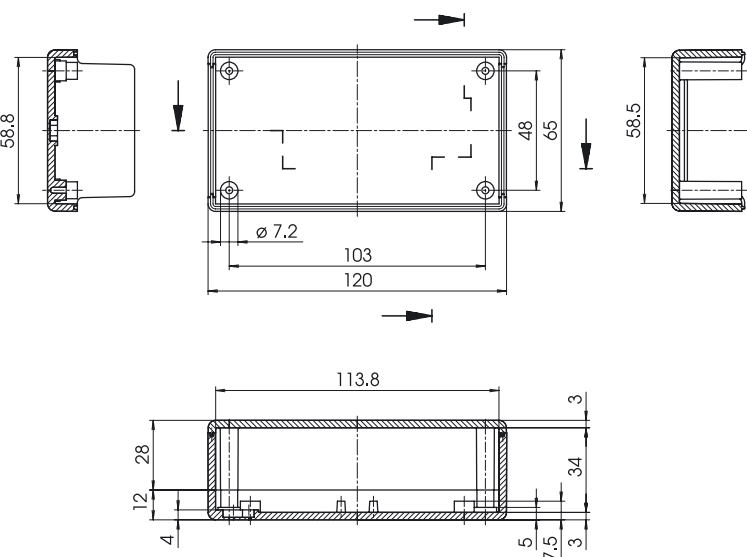

**E 430  
E 435**

Z-2801044

# Element

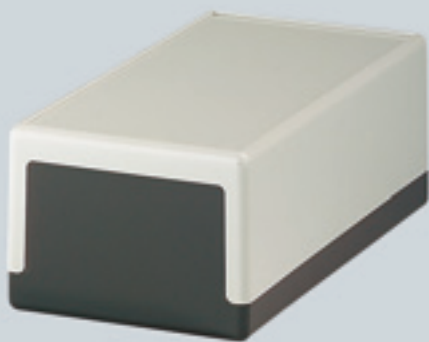

E 440 F

## Element enclosures E 440 (F VL) / 445

Order designation		Ext. dimensions		
Model	Order no.	L	W	H
E 440	05440002	150	80	55
E 440 F*	05440700	150	80	56
E 440 F VL*	05440800	150	80	56
E 440 VL*	05440200	150	80	55
E 445*	05445000	150	80	80**

- F = with membrane area
- F VL = with membrane area and with vertically moulded-in air vents
- VL = with vertically moulded-in air vents

- \* available on request
- \*\* other dimensions similar to E 440
- lid with threaded insert for screwing base

Version E 440 F

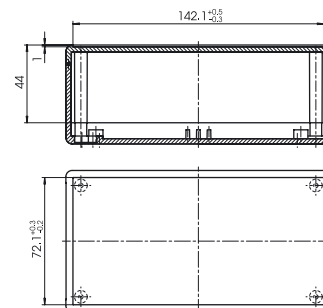

Version E 440 FVL

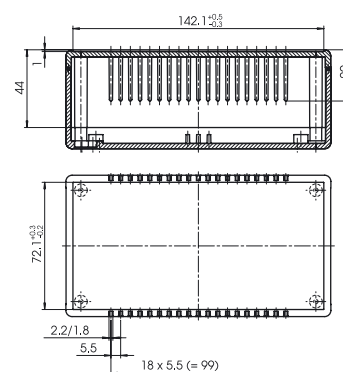

## Element enclosures E 450 / 460 / 470

Order designation		Ext. dimensions		
Model	Order no.	L	W	H
E 450	05450002	188	110	70
E 450 F*	05450700	188	110	71
E 450 F VL*	05450800	188	110	71
E 450 VL*	05450200	188	110	70
E 460*	05460000	188	110	100**
E 470*	05470000	188	110	120**
E 434 S	05434000	188	110	40**

- F = with membrane area
- F VL = with membrane area and with vertically moulded-in air vents
- VL = with vertically moulded-in air vents
- S = with snap lock

- \* available on request
- \*\* other dimensions similar to E 450
- lid with threaded insert for screwing base

Version E 450 F

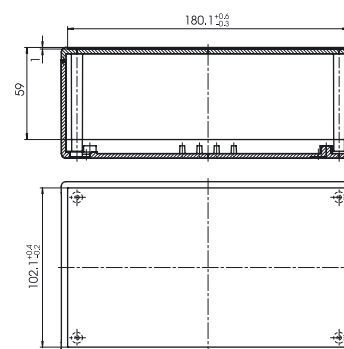

Version E 450 FVL

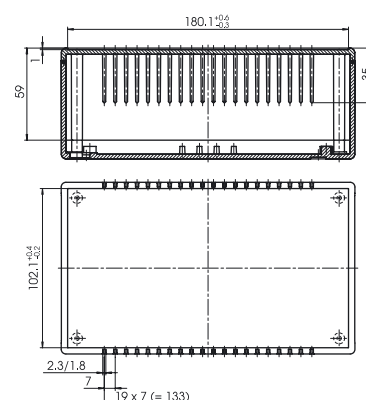

E 450 F VL

View into the base (E 440)

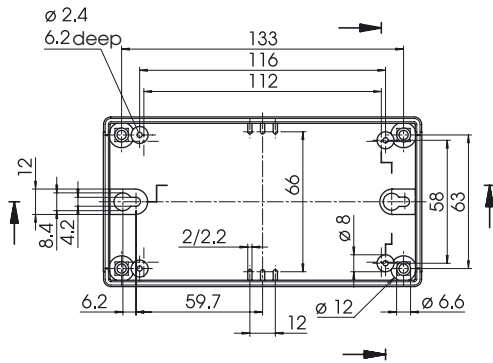

View into the lid (E 440)

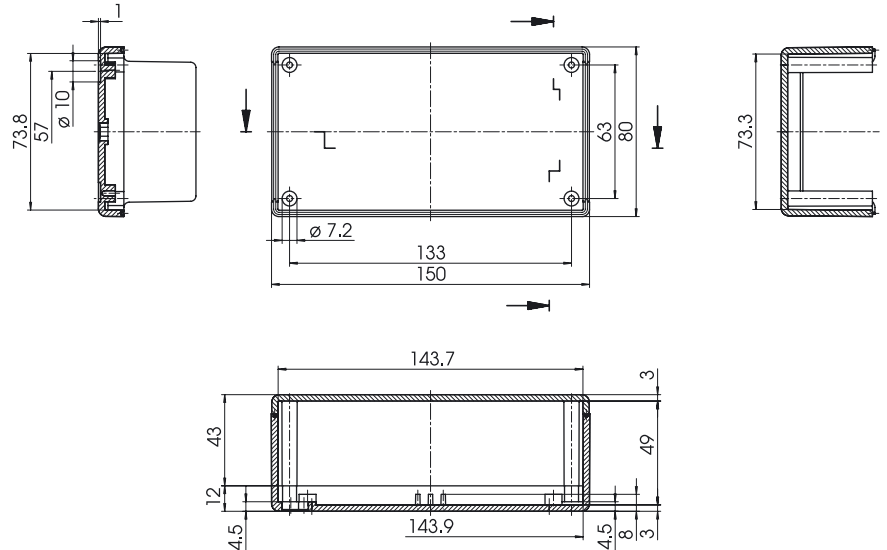

E 440  
E 445

Z-2801045

View into the base (E 450)

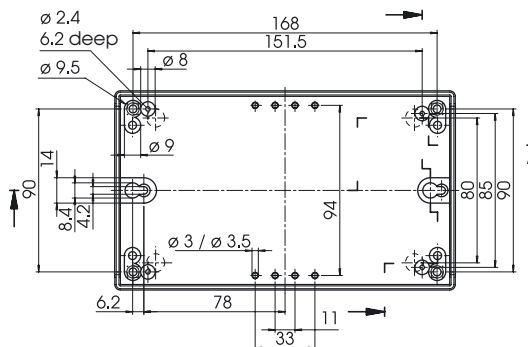

View into the lid (E 450)

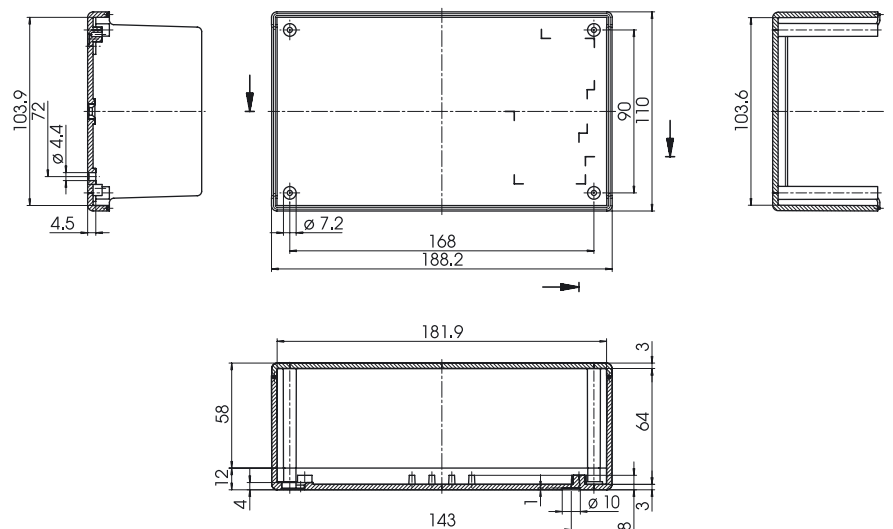

E 450  
E 460  
E 470

Z-2801046





# Element accessories



Lid fixing E-DO  
for screwing lid from on top; this ensures fast access to the electronic components when wall-mounted enclosures need to be serviced.  
(Enclosure lid must be processed)

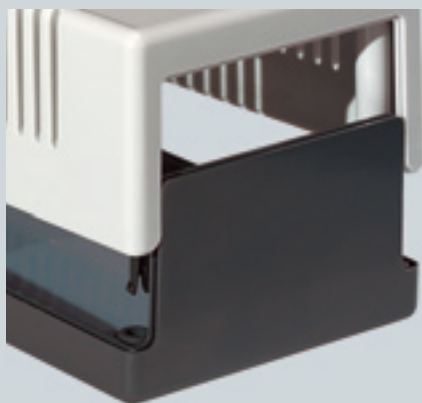

Snap lock E-SV  
for fast, easy assembly of the enclosure shells.

Accessories ▶ Enclosures ▼	Lid fixing E-DO	Snap lock E-SV
E 406	-	-
E 406 VL	-	-
E 406 F	-	-
E 408	-	-
E 410	-	-
E 410 F	-	-
E 410 F VL	-	-
E 420	-	-
E 420 F	-	-
E 420 F VL	-	-
E 430	<b>25000500</b>	-
E 430 F	-	-
E 430 F VL	-	-
E 430 A	-	-
E 435	<b>25000600</b>	<b>25001700</b>
E 440	<b>25000700</b>	-
E 440 VL*	<b>25000700</b>	<b>25001700</b>
E 440 F	-	-
E 440 F VL*	-	-
E 445	<b>25000800</b>	<b>25001700</b>
E 450	<b>25000910</b>	-
E 450 VL*	<b>25000910</b>	<b>25001700</b>
E 450 F	-	-
E 450 F VL*	-	-
E 460	<b>25001000</b>	<b>25001700</b>
E 470	<b>25001100</b>	<b>25001700</b>
E 434 S	-	-

\* available on request

<b>Scope of delivery:</b>	1 set = 4 screws	1 set = 4 pieces
	4 inserts	

Accessories ▶ Enclosures ▼	Mounting plate E-M	Rubber feet E-F	Wall bracket E-WL
E 406	–	25002100	25001500
E 406 VL	–	25002100	25001500
E 406 F	–	25002100	25001500
E 408	–	25002100	25001500
E 410	25000100*	25002100	25001500
E 410 F	25000100*	25002100	25001500
E 410 F VL	25000100*	25002100	25001500
E 420	25000100*	25002100	25001500
E 420 F	25000100*	25002100	25001500
E 420 F VL	25000100*	25002100	25001500
E 430	25000200*	25002100	25001500
E 430 F	25000200*	25002100	25001500
E 430 F VL	25000200*	25002100	25001500
E 430 A	25000200*	25002100	25001500
E 435	25000200*	25002100	25001500
E 440	25000400	25002200	25001500
E 440 VL	25000400	25002200	25001500
E 440 F	25000400	25002200	25001500
E 440 F VL	25000400	25002200	25001500
E 445	25000400	25002200	25001500
E 450	25000300*	25002200	25001500
E 450 VL	25000300*	25002200	25001500
E 450 F	25000300*	25002200	25001500
E 450 F VL	25000300*	25002200	25001500
E 460	25000300*	25002200	25001600
E 470	25000300*	25002200	25001600
E 434 S	25000300*	25002200	–

\* available on request

Scope of delivery: 1 piece

1 set = 4 pieces

1 set = 4 wall  
brackets, 4 screws

### Wall brackets E-WL

Model	A	B	C	D	E	F
E 406..	77	48	33	62	3.4	3.1
E 408..	77	48	33	62	3.4	3.1
E 410..	112	83	33	62	3.4	3.1
E 420..	112	83	33	62	3.4	3.1
E 430..	132	103	48	77	3.4	3.1
E 434	–	–	–	–	–	–
E 435	132	103	48	77	3.4	3.1
E 440..	162	133	63	92	3.4	3.1
E 445	162	133	63	92	3.4	3.1
E 450	–	–	–	–	–	–
E 450 F	197	168	90	119	3.4	3.1
E 450 F VL	–	–	–	–	–	–
E 450 VL	202	168	90	124	4.4	4.5
E 460	202	168	90	124	4.4	4.5
E 470	202	168	90	124	4.4	4.5

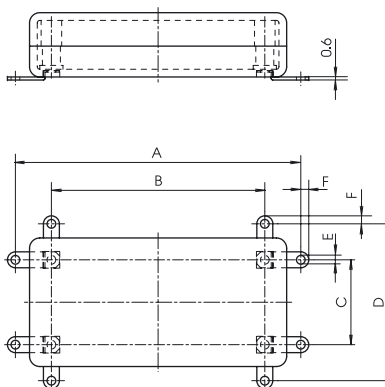

Mounting plate E-M  
for mounting constructions.  
Can be screwed onto mounting  
bosses in the base.



Rubber feet E-F  
guarantee safe, non-slip use.



Wall bracket E-WL  
for screwing the pre-assembled  
complete enclosure into position  
without opening the enclosure.

Z-2800939