



Four new flat versions round off this innovative and successful IP 65 enclosure line.

Made from either high-quality polycarbonate or from lower-priced ABS, this enclosure line offers a wide range of benefits thanks to its easy-to-use screw-mounting system and the additional mounting bosses in the base. The versions with a recessed membrane keypad area (-F) and/or PCB

The Euroflat line

In addition to the mounting bosses, a PCB can be clamp-fitted between the upper and lower sections.

More space is available because there are no bosses for terminal blocks.

Some come with mounting bosses for Eurocard 100 x 160 mm and 100 x 220 mm in the lower section.

plug-in slots (-LP/FLP) are ideal for use as electronic enclosures.

This enclosure is especially easy to recycle because there are no moulded-in metal parts, and in each case only one type of plastic is used.

Enclosure material: Polycarbonate or ABS. For technical data see pages 646-651.

Colour: Light grey, similar to RAL 7035. Special colours on request.

Scope of delivery: Upper and lower section; self-tapping coarse thread lid screws made of V2A; max. unscrewing force 45 Ncm.

Ingress protection: IP 65/DIN EN 60529; increased protection on request.

Lid seal: Sponge cord (neoprene) in lid groove. For technical data see page 651.

Accessories (additional charge):

M: Mounting plate, laminated paper (Pertinax)
 SA: Screw covers, 1 set = 6 pcs
 GF: Set of rubber feet = 4 pcs
 WL: Set of wall brackets = 4 pcs
 TS 15: Top hat rail DIN EN 60715 TH15
 TS 32: G-rail DIN EN 60715 G 32
 TS 35: Top hat rail DIN EN 60715 TH35

Notes:

- **F-version** with recessed area in upper section for flush-fitting of membrane keypads
- **LP-version** in lower section with plug-in slots for PCBs
- We recommend fitting the mounting plate or the DIN-rails with self-tapping screws, see page 642
- Cable glands, see page page 614 ff.
- Terminal assignment, see page 387
- Material shrinkage may result in ABS enclosures being approx. 0.1 - 0.25% larger than the PC enclosures illustrated

Off-set bosses for clamping rectangular PCBs or mounting plates (not included in BOPLA range).

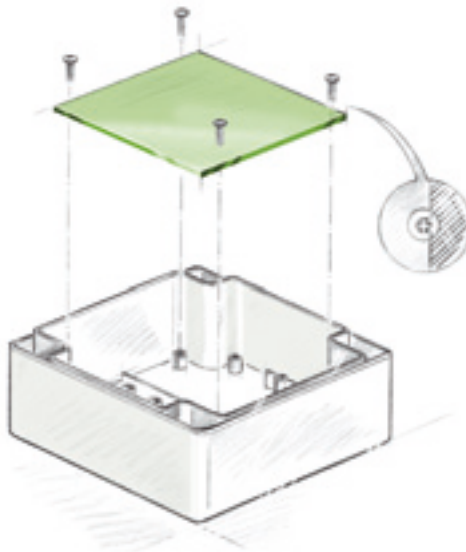

Standard mounting plate fixing, incl. some which can be fitted in the lid.

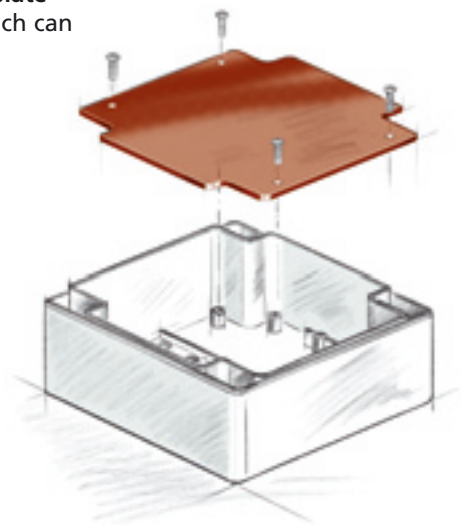

Bosses for terminal blocks (Type KL 16, Wieland).

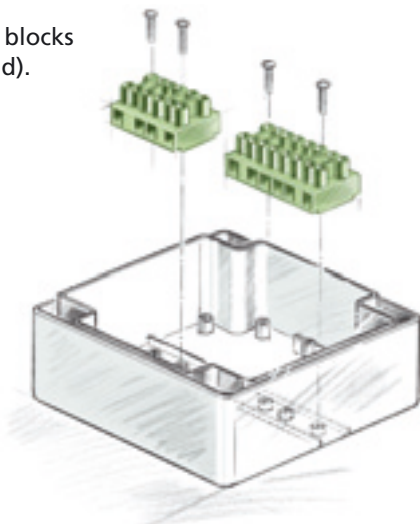

Bosses with side support pins for non-tilt DIN-rail assembly.

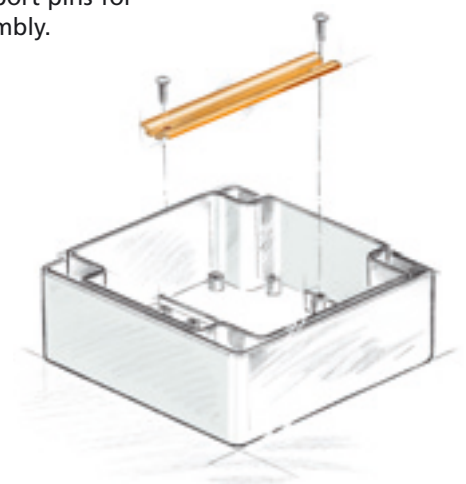

Euromas II

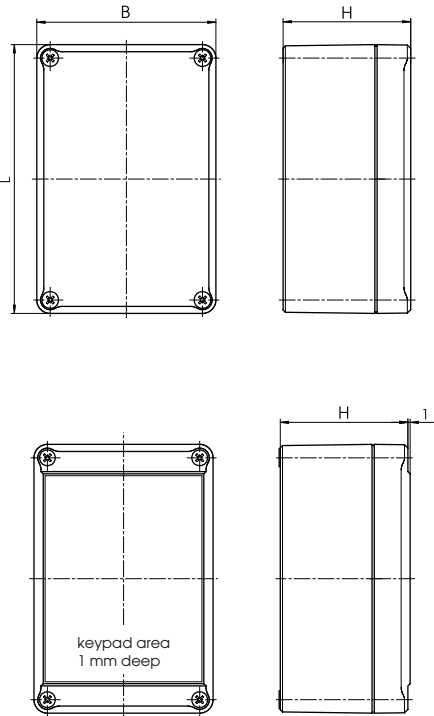

Polycarbonate enclosures		ABS enclosures		Size		
Model	Order no.	Model	Order no.	L	W	H
EM 205	62205000	ET 205	63205000	52	50	37
EM 205 F	62205200	ET 205 F	63205200	52	50	37
EM 206	62206000	ET 206	63206000	65	50	37
EM 206 F	62206200	ET 206 F	63206200	65	50	37
EM 207 LP	62207300	ET 207 LP	63207300	82	60	57
EM 207 F-LP	62207400	ET 207 F-LP	63207400	82	60	57
EM 208	62208000	ET 208	63208000	98	64	38
EM 208 F	62208200	ET 208 F	63208200	98	64	38
EM 210	62210000	ET 210	63210000	82	80	57
EM 210 F	62210200	ET 210 F	63210200	82	80	57
EM 212	62212000	ET 212	63212000	100	100	57
EM 212 F	62212200	ET 212 F	63212200	100	100	57
EM 213*	62213000	ET 213	63213000	122	120	37
EM 213 F*	62213200	ET 213 F	63213200	122	120	37
EM 214 LP	62214300	ET 214 LP	63214300	200	120	57
EM 214 F-LP	62214400	ET 214 F-LP	63214400	200	120	57
EM 215	62215000	ET 215	63215000	120	80	57
EM 215 F	62215200	ET 215 F	63215200	120	80	57
EM 217	62217000	ET 217	63217000	122	120	57
EM 217 F	62217200	ET 217 F	63217200	122	120	57
EM 218 LP	62218300	ET 218 LP	63218300	150	150	57
EM 218 F-LP	62218400	ET 218 F-LP	63218400	150	150	57
EM 220	62220000	ET 220	63220000	160	80	57
EM 220 F	62220200	ET 220 F	63220200	160	80	57
EM 221	62221000	ET 221	63221000	200	120	77
EM 221 F	62221200	ET 221 F	63221200	200	120	77
EM 223	62223000	ET 223	63223000	200	150	77
EM 223 F	62223200	ET 223 F	63223200	200	150	77
EM 224 LP	62224300	ET 224 LP	63224300	240	80	60
EM 224 F-LP	62224400	ET 224 F-LP	63224400	240	80	60
EM 225	62225000	ET 225	63225000	82	80	87
EM 225 F	62225200	ET 225 F	63225200	82	80	87
EM 227	62227000	ET 227	63227000	122	120	87
EM 227 F	62227200	ET 227 F	63227200	122	120	87
EM 229*	62229000	ET 229	63229000	160	80	37
EM 229 F*	62229200	ET 229 F	63229200	160	80	37
EM 231	62231000	ET 231	63231000	160	80	87
EM 231 F	62231200	ET 231 F	63231200	160	80	87
EM 232*	62232000	ET 232	63232000	200	150	37
EM 232 F*	62232200	ET 232 F	63232200	200	150	37
EM 233*	62233000	ET 233	63233000	250	160	37
EM 233 F*	62233200	ET 233 F	63233200	250	160	37
EM 236 LP	62236300	ET 236 LP	63236300	240	80	80
EM 236 F-LP	62236400	ET 236 F-LP	63236400	240	80	80
EM 237	62237000	ET 237	63237000	200	120	92
EM 237 F	62237200	ET 237 F	63237200	200	120	92
EM 238	62238000	ET 238	63238000	160	120	92
EM 238 F	62238200	ET 238 F	63238200	160	120	92
EM 239	62239000	ET 239	63239000	250	160	57
EM 239 F	62239200	ET 239 F	63239200	250	160	57
EM 240	62240000	ET 240	63240000	250	160	92
EM 240 F	62240200	ET 240 F	63240200	250	160	92
EM 241	62241000	ET 241	63241000	250	160	122
EM 241 F	62241200	ET 241 F	63241200	250	160	122
EM 242	62242000	ET 242	63242000	240	120	102
EM 242 F	62242200	ET 242 F	63242200	240	120	102
EM 247 LP	62247300	ET 247 LP	63247300	300	160	120
EM 247 F-LP	62247400	ET 247 F-LP	63247400	300	160	120

Note

For Euromas II enclosures an additional model with PCB slots EM/ET...LP is available on request.

= The Euroflat line

Order designation

Model	Material	Order no.	▶
EM 205	PC	62205000	
ET 205	ABS	63205000	

Model	Material	Order no.	▼
EM 205 F	PC	62205200	
ET 205 F	ABS	63205200	

(F = with membrane keypad area)

EM/ET 205 (F)

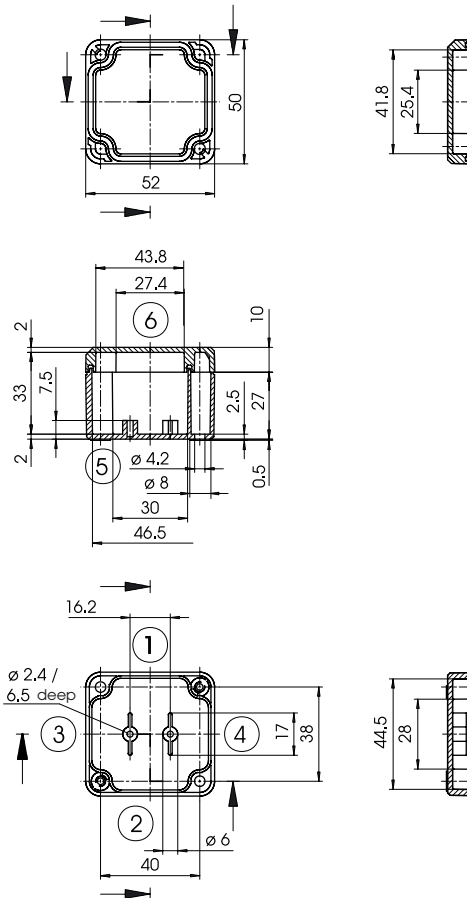
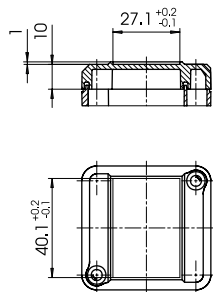

Z-2500872

Order designation

Model	Material	Order no.	▶
EM 206	PC	62206000	
ET 206	ABS	63206000	

Model	Material	Order no.	▼
EM 206 F	PC	62206200	
ET 206 F	ABS	63206200	

(F = with membrane keypad area)

EM/ET 206 (F)

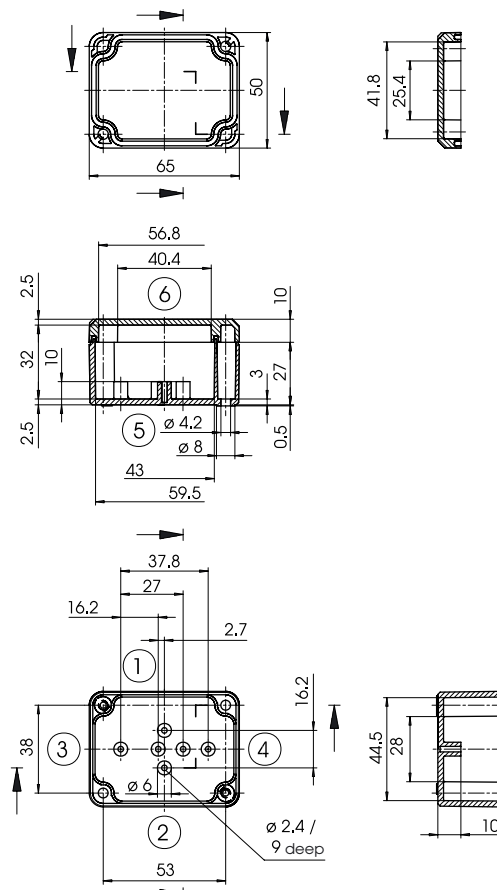
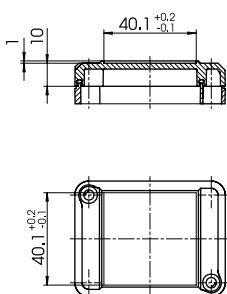

Z-2500873

Euromas II

EM/ET 207 (F) LP

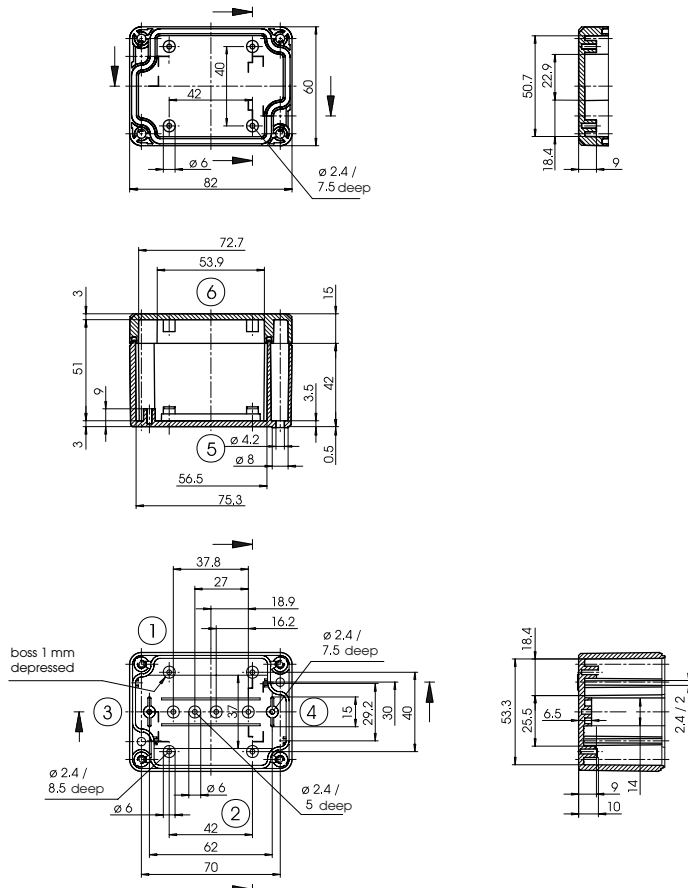

Order designation

Model	Material	Order no.
EM 207 LP	PC	62207300
ET 207 LP	ABS	63207300

Model	Material	Order no.
EM 207 F-LP	PC	62207400
ET 207 F-LP	ABS	63207400

(F = with membrane keypad area, LP = with PCB plug-in slots)

Z-2500874

EM/ET 208 (F)

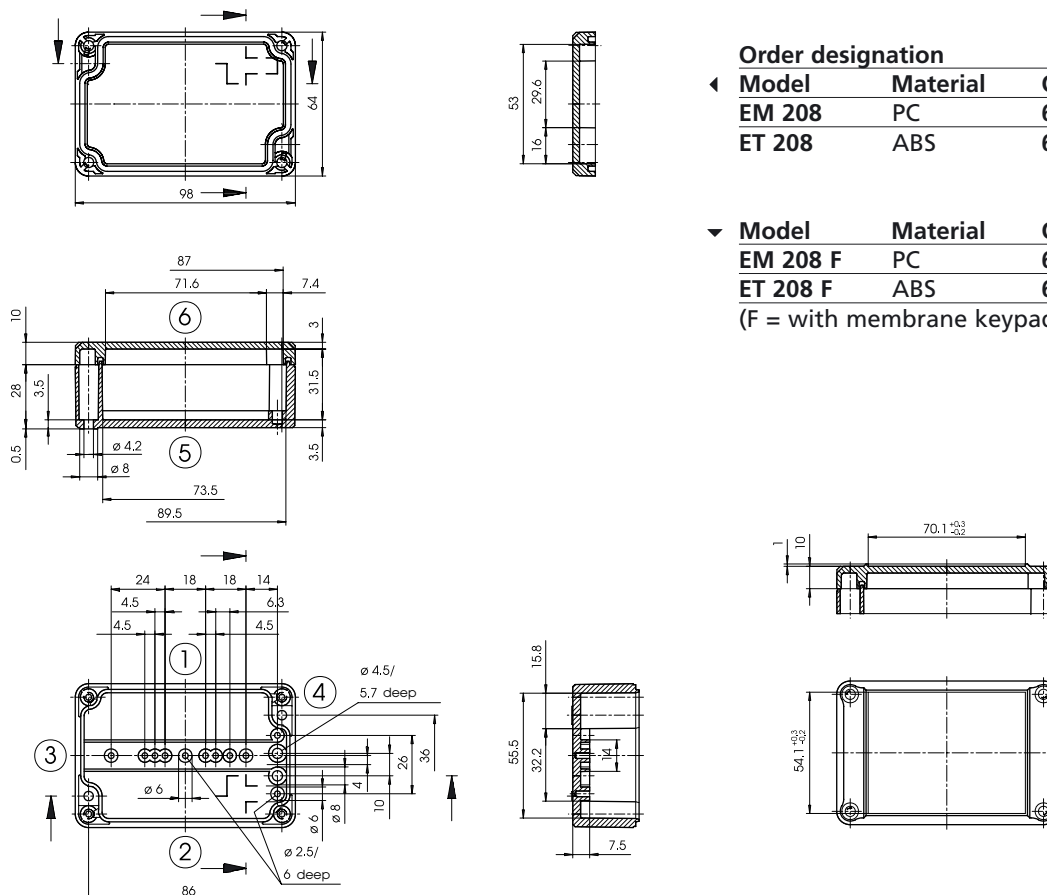

Order designation

Model	Material	Order no.
EM 208	PC	62208000
ET 208	ABS	63208000

Model	Material	Order no.
EM 208 F	PC	62208200
ET 208 F	ABS	63208200

(F = with membrane keypad area)

Z-2500875

Order designation

Model	Material	Order no.
EM 210	PC	62210000
ET 210	ABS	63210000

Model	Material	Order no.
EM 210 F	PC	62210200
ET 210 F	ABS	63210200

(F = with membrane keypad area)

EM/ET 210 (F)

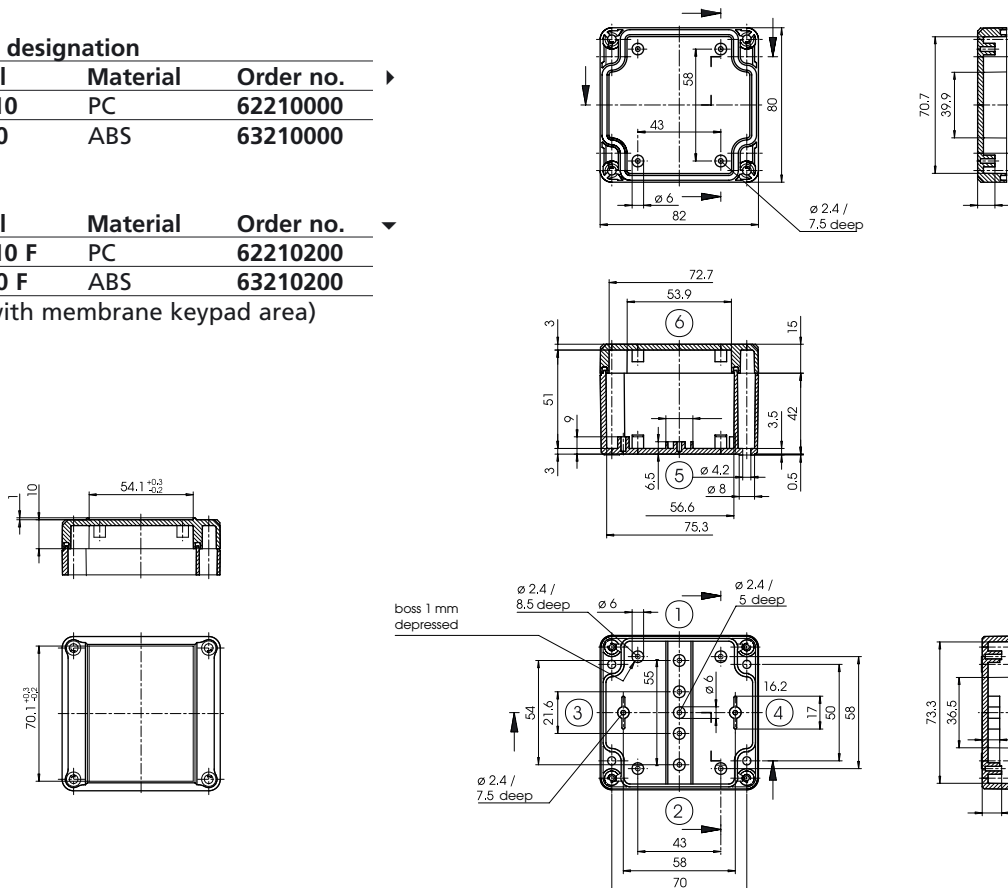

Z-2500876

Order designation

Model	Material	Order no.
EM 212	PC	62212000
ET 212	ABS	63212000

Model	Material	Order no.
EM 212 F	PC	62212200
ET 212 F	ABS	63212200

(F = with membrane keypad area)

EM/ET 212 (F)

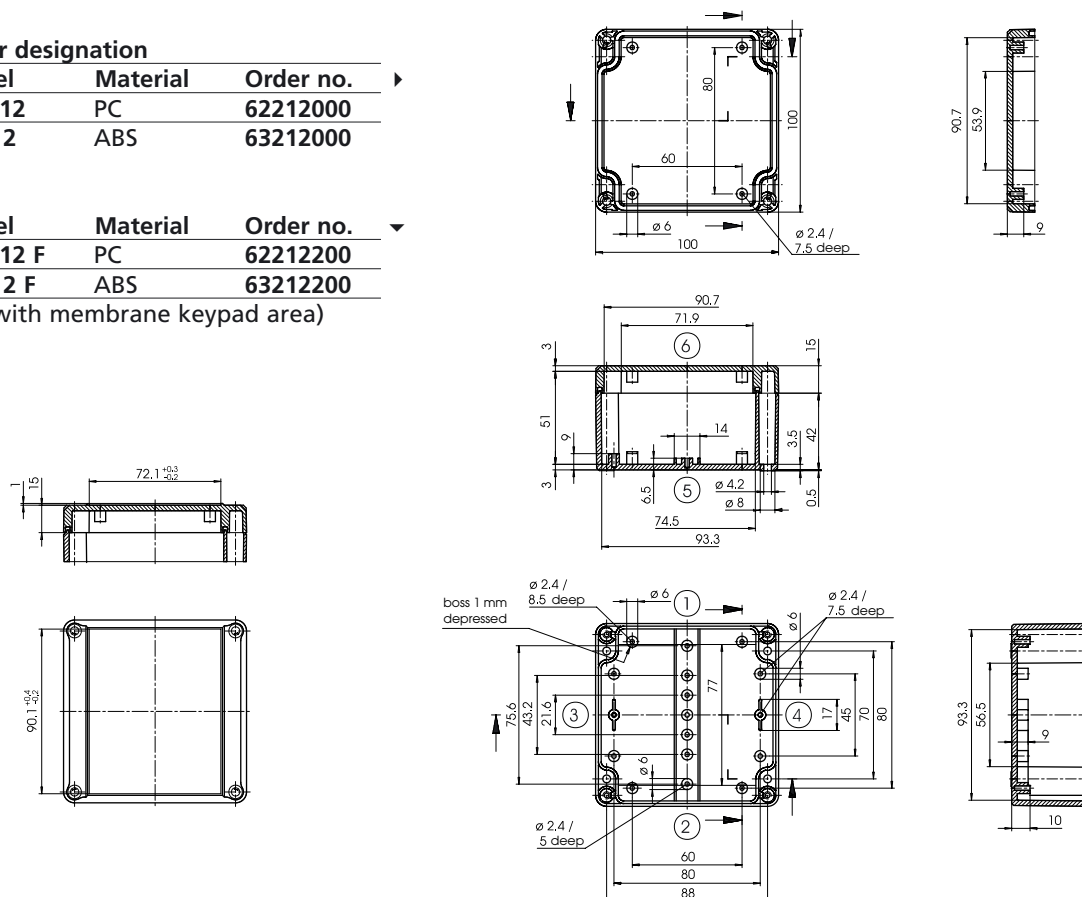

Z-2500877

Euromas II

EM/ET 213 (F)

In addition to the mounting bosses, a PCB can be clamped between the upper and lower sections. More space is available because there are no bosses for terminal blocks.

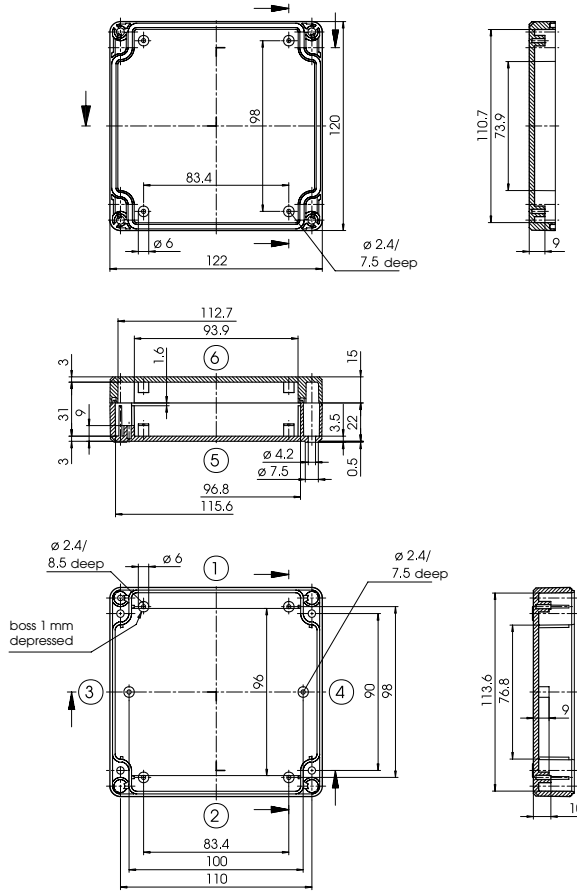

Z-2501705

Order designation

Model	Material	Order no.
EM 213*	PC	62213000
ET 213	ABS	63213000

Model	Material	Order no.
EM 213 F*	PC	62213200
ET 213 F	ABS	63213200

(F = with membrane keypad area)

* available on request

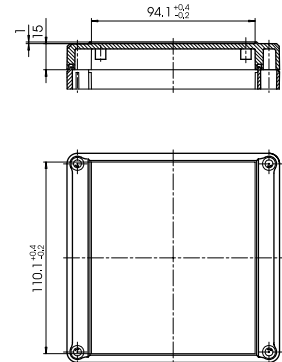

EM/ET 214 (F) LP

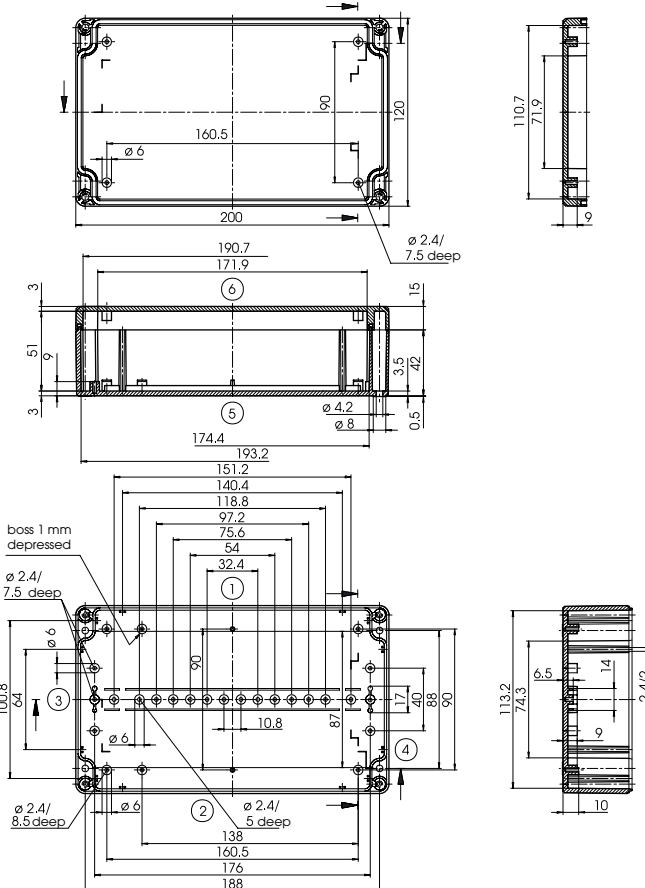

Z-2501001

Order designation

Model	Material	Order no.
EM 214 LP	PC	62214300
ET 214 LP	ABS	63214300

Model	Material	Order no.
EM 214 F-LP	PC	62214400
ET 214 F-LP	ABS	63214400

(F = with membrane keypad area, LP = with PCB plug-in slots)

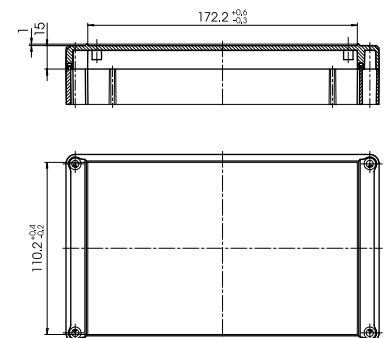

Order designation

Model	Material	Order no.
EM 215	PC	62215000
ET 215	ABS	63215000

Model	Material	Order no.
EM 215 F	PC	62215200
ET 215 F	ABS	63215200

(F = with membrane keypad area)

EM/ET 215 (F)

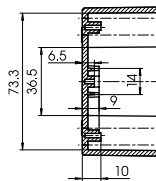
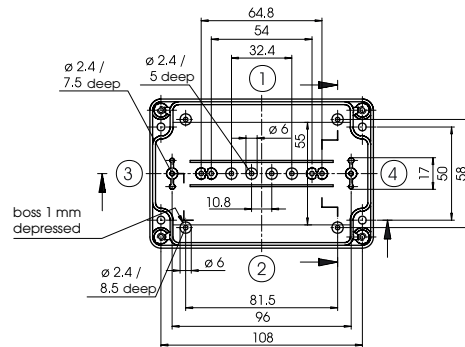
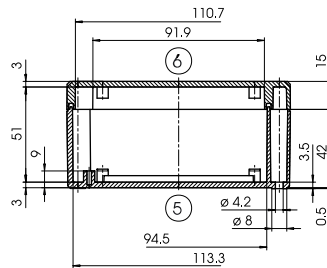
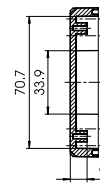
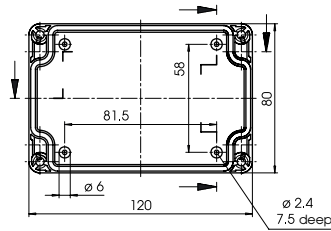

Z-2500878

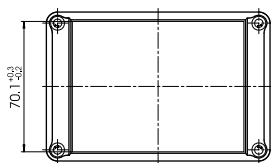
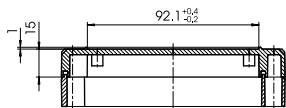

Order designation

Model	Material	Order no.
EM 217	PC	62217000
ET 217	ABS	63217000

Model	Material	Order no.
EM 217 F	PC	62217200
ET 217 F	ABS	63217200

(F = with membrane keypad area)

EM/ET 217 (F)

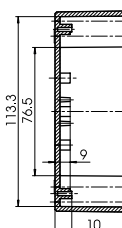
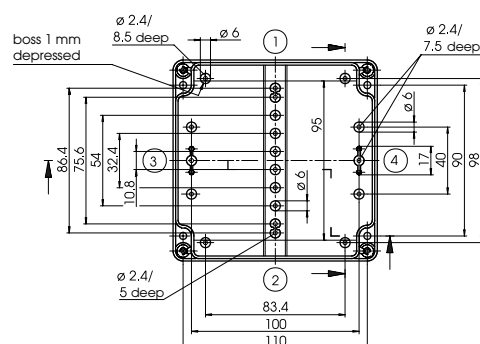
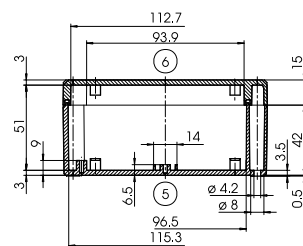
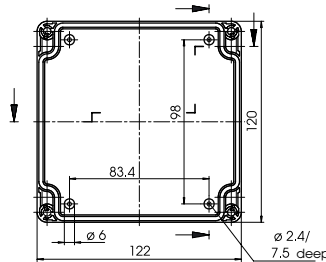

Z-250983

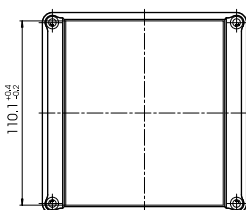
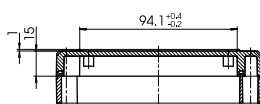

Euromas II

EM/ET 218 (F) LP

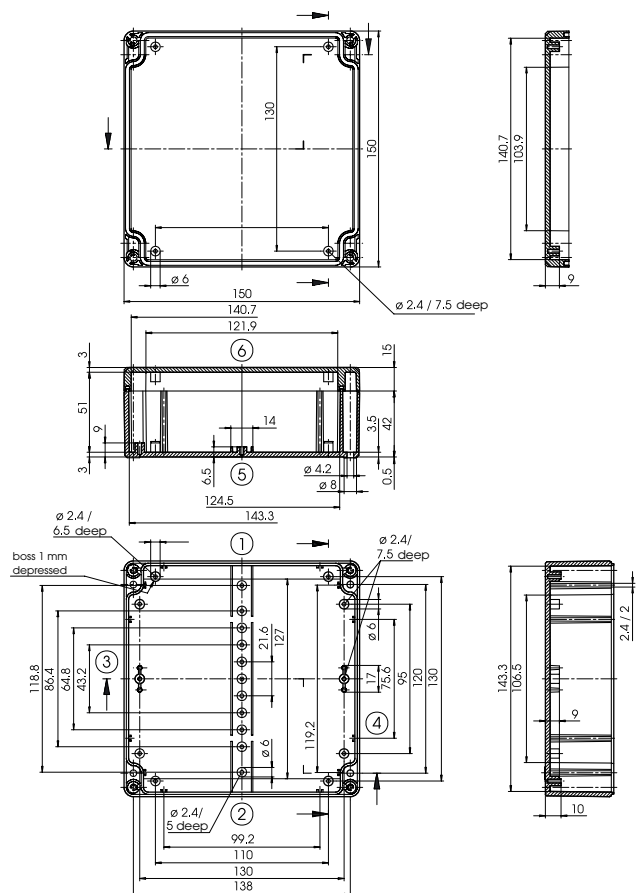

Order designation

Model	Material	Order no.
EM 218 LP	PC	62218300
ET 218 LP	ABS	63218300

Model	Material	Order no.
EM 218 F-LP	PC	62218400
ET 218 F-LP	ABS	63218400

(F = with membrane keypad area, LP = with PCB plug-in slots)

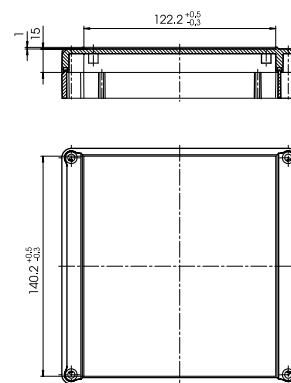

Z-2500871

EM/ET 220 (F)

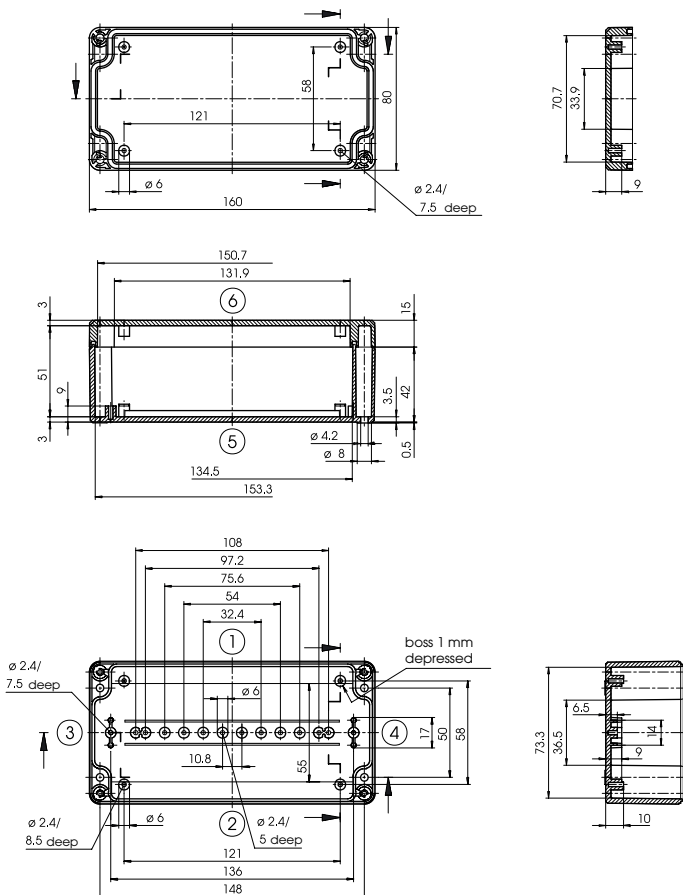

Order designation

Model	Material	Order no.
EM 220	PC	62220000
ET 220	ABS	63220000

Model	Material	Order no.
EM 220 F	PC	62220200
ET 220 F	ABS	63220200

(F = with membrane keypad area)

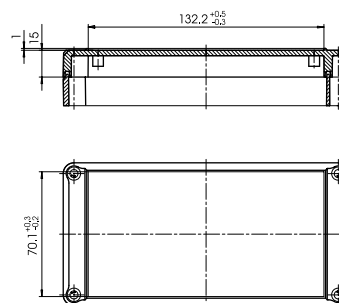

Z-2500879

Order designation

Model	Material	Order no.	▶
EM 221	PC	62221000	
ET 221	ABS	63221000	

Model	Material	Order no.	▼
EM 221 F	PC	62221200	
ET 221 F	ABS	63221200	

(F = with membrane keypad area)

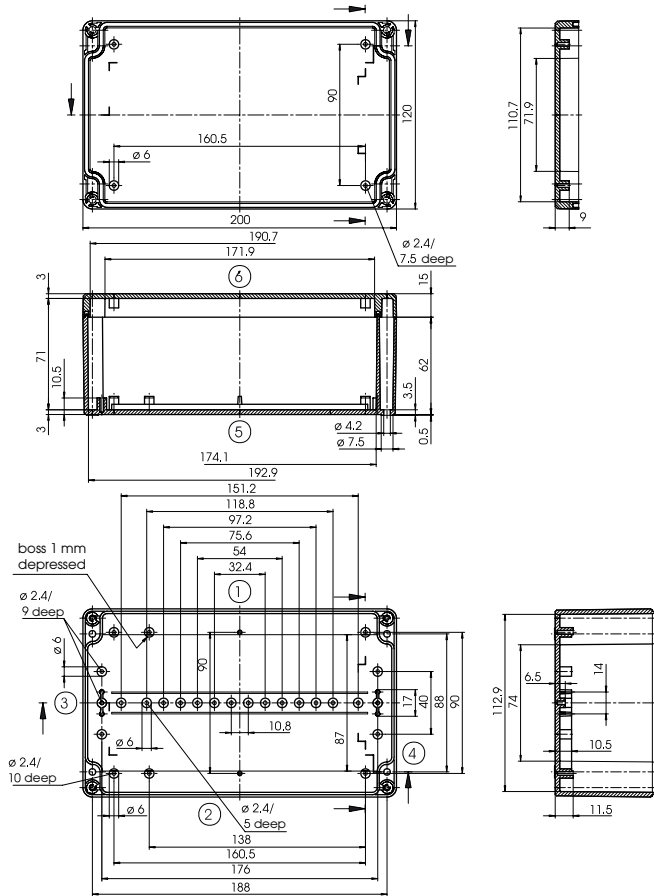
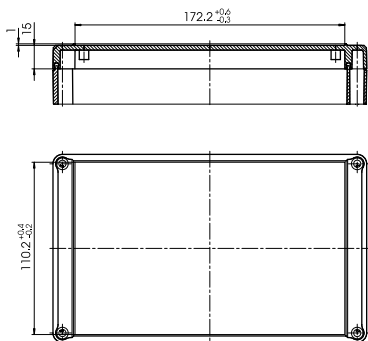

EM/ET 221 (F)

Z-2500880

Order designation

Model	Material	Order no.	▶
EM 223	PC	62223000	
ET 223	ABS	63223000	

Model	Material	Order no.	▼
EM 223 F	PC	62223200	
ET 223 F	ABS	63223200	

(F = with membrane keypad area)

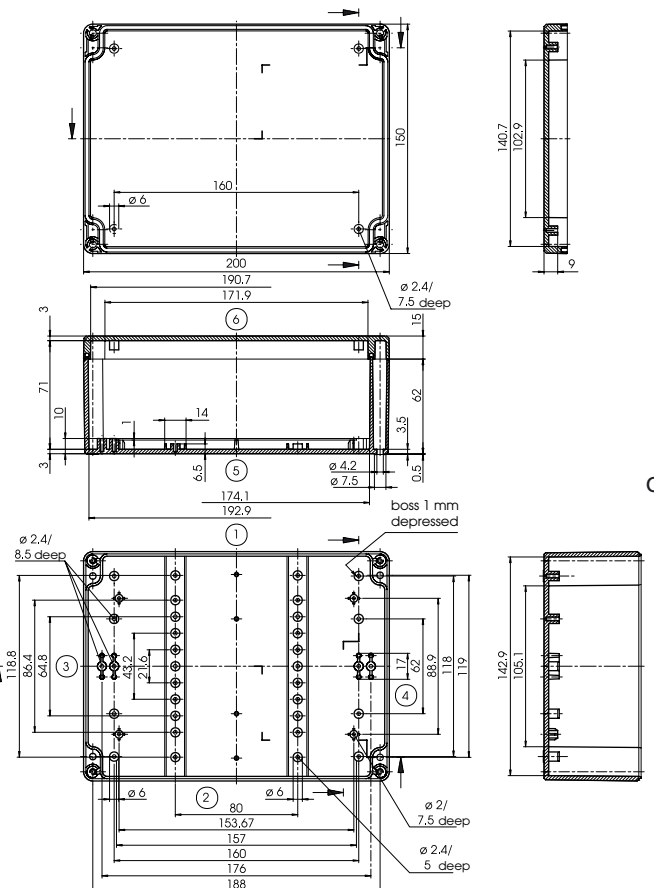
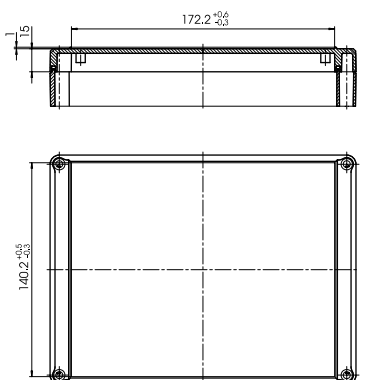

EM/ET 223 (F)

This model has additional bosses to permit fitting of a Eurocard 100 x 160. Please order the appropriate mounting set EM/ET 223-BS 160 separately. Order no. 22223002.

Z-2500997

Euromas II

EM/ET 224 (F) LP

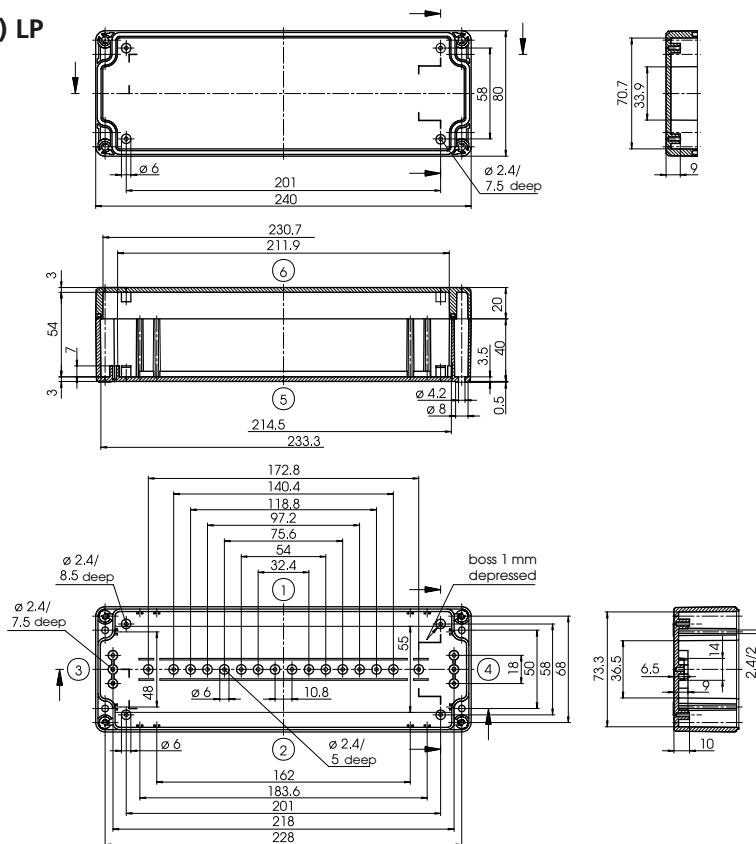

Order designation

Model	Material	Order no.
EM 224 LP	PC	62224300
ET 224 LP	ABS	63224300

Model	Material	Order no.
EM 224 F-LP	PC	62224400
ET 224 F-LP	ABS	63224400

(F = with membrane keypad area, LP = with PCB plug-in slots)

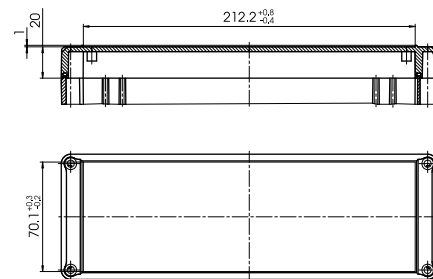

Z-2500974

EM/ET 225 (F)

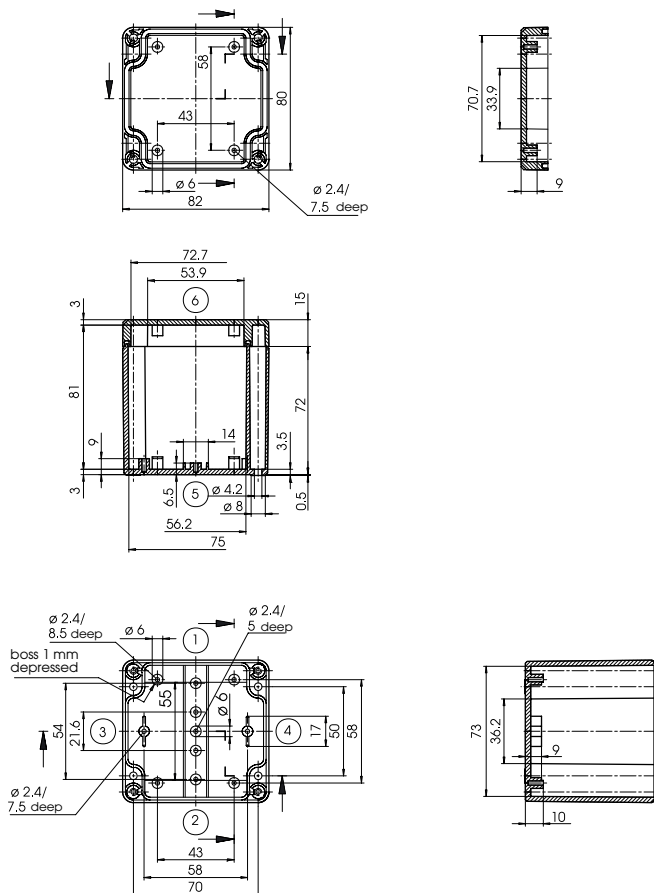

Order designation

Model	Material	Order no.
EM 225	PC	62225000
ET 225	ABS	63225000

Model	Material	Order no.
EM 225 F	PC	62225200
ET 225 F	ABS	63225200

(F = with membrane keypad area)

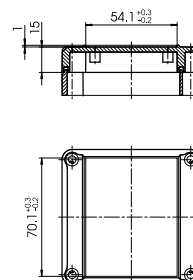

Z-2501000

Order designation

Model	Material	Order no.
EM 227	PC	62227000
ET 227	ABS	63227000

Model	Material	Order no.
EM 227 F	PC	62227200
ET 227 F	ABS	63227200

(F = with membrane keypad area)

EM/ET 227 (F)

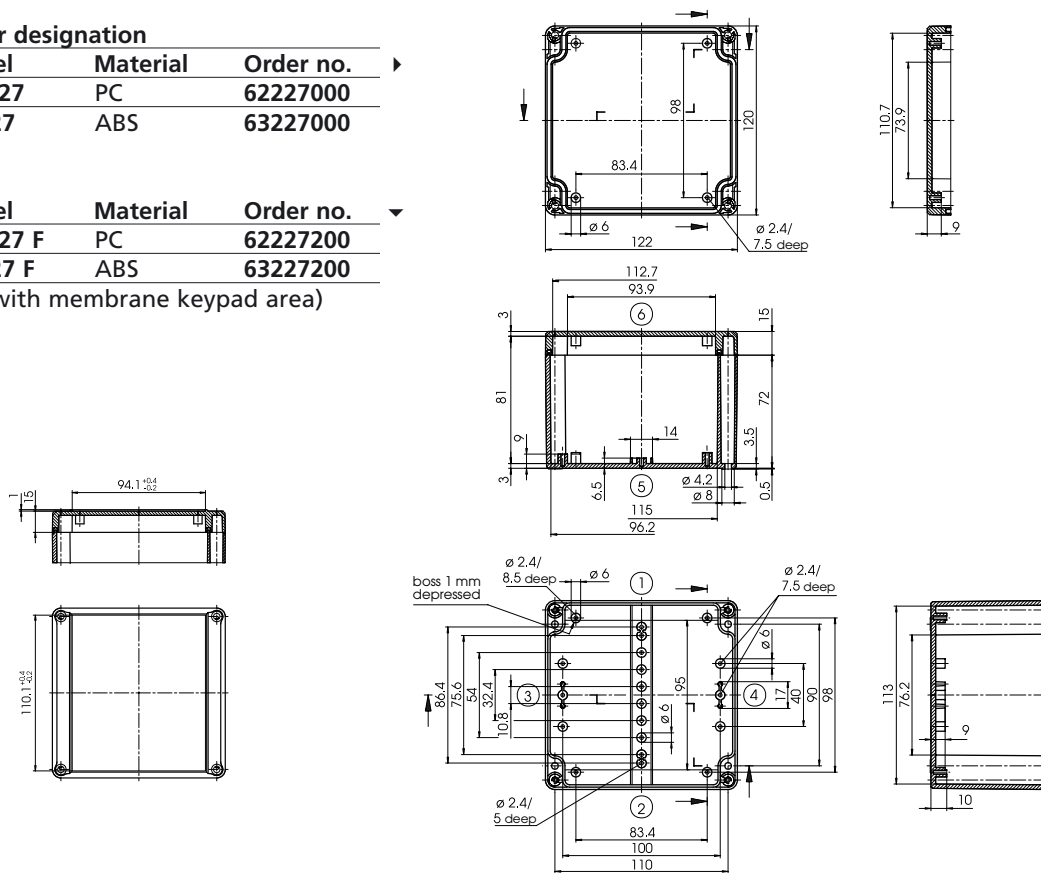

Z-2500984

Order designation

Model	Material	Order no.
EM 229*	PC	62229000
ET 229	ABS	63229000

Model	Material	Order no.
EM 229 F*	PC	62229200
ET 229 F	ABS	63229200

(F = with membrane keypad area)

* available on request

EM/ET 229 (F)

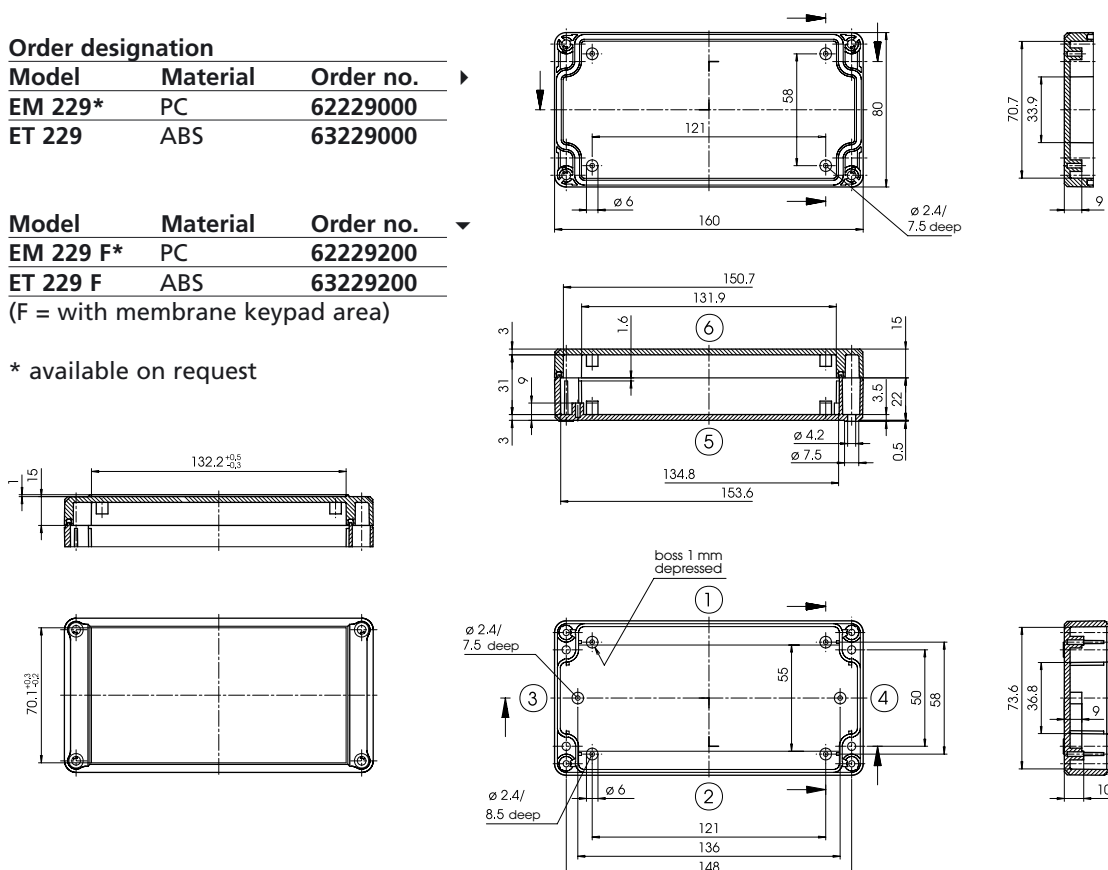

In addition to the mounting bosses, a PCB can be clamp-fitted between the upper and lower sections. More space is available because there are no bosses for terminal blocks.

Z-2501706

Euromas II

EM/ET 231 (F)

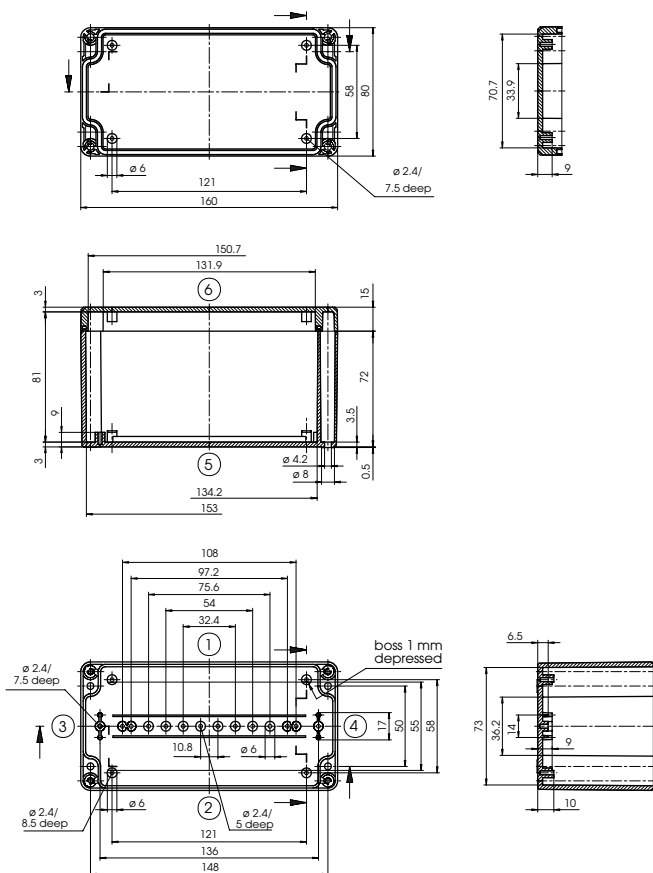

Order designation

Model	Material	Order no.
EM 231	PC	62231000
ET 231	ABS	63231000

Model	Material	Order no.
EM 231 F	PC	62231200
ET 231 F	ABS	63231200

(F = with membrane keypad area)

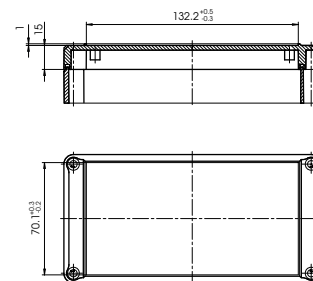

Z-2500907

EM/ET 232 (F)

In addition to the mounting bosses, a PCB can be clamp-fitted between the upper and lower sections. More space is available because there are no bosses for terminal blocks.

With mounting bosses for Euro-card 100 x 160 mm in the lower section.

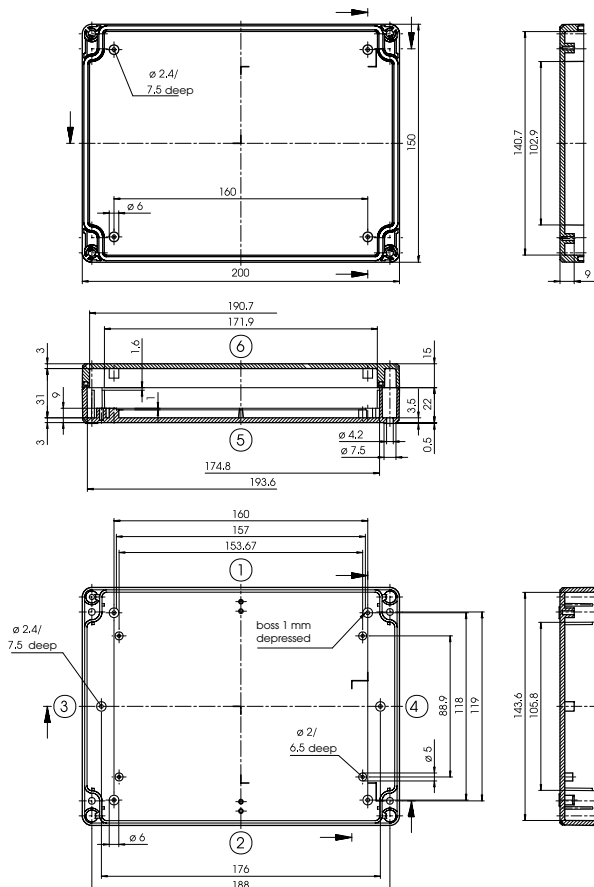

Order designation

Model	Material	Order no.
EM 232*	PC	62232000
ET 232	ABS	63232000

Model	Material	Order no.
EM 232 F*	PC	62232200
ET 232 F	ABS	63232200

(F = with membrane keypad area)

* available on request

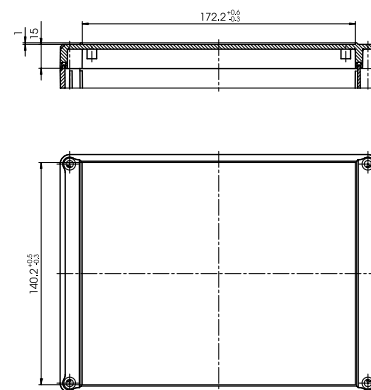

Z-2501707

Order designation

Model	Material	Order no.	▶
EM 233*	PC	62233000	
ET 233	ABS	63233000	

Model	Material	Order no.	▼
EM 233 F*	PC	62233200	
ET 233 F	ABS	63233200	

(F = with membrane keypad area)

* available on request

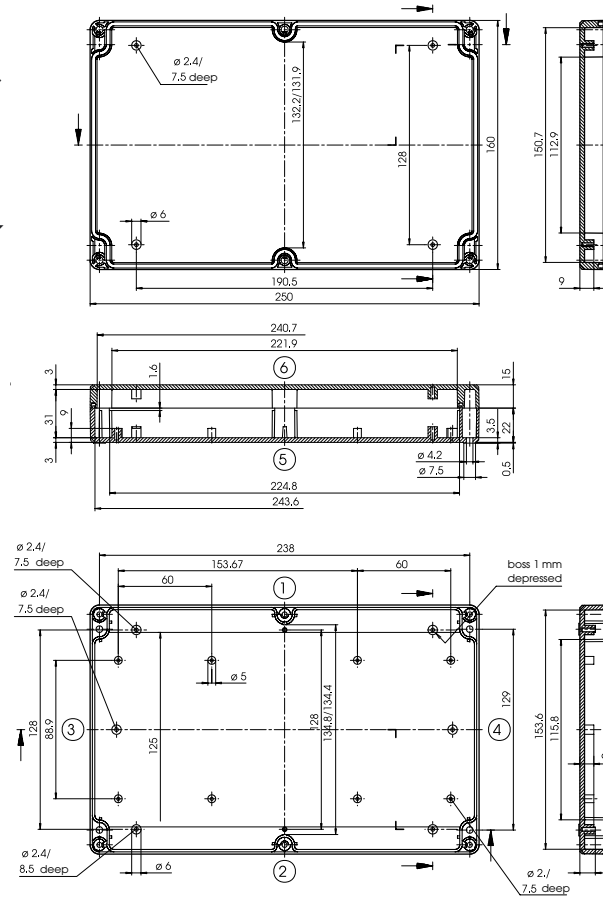
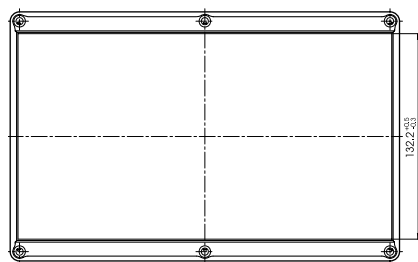
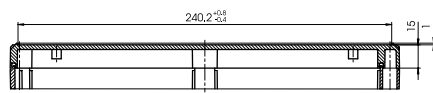

EM/ET 233(F)

In addition to the mounting bosses, a PCB can be clamp-fitted between the upper and lower sections. More space is available because there are no bosses for terminal blocks.

With mounting bosses for Euro-card 100 x 160 mm and 100 x 220 mm in the lower section.

Z-2501708

Order designation

Model	Material	Order no.	▶
EM 236 LP	PC	62236300	
ET 236 LP	ABS	63236300	

Model	Material	Order no.	▼
EM 236 F-LP	PC	62236400	
ET 236 F-LP	ABS	63236400	

(F = with membrane keypad area, LP = with PCB plug-in slots)

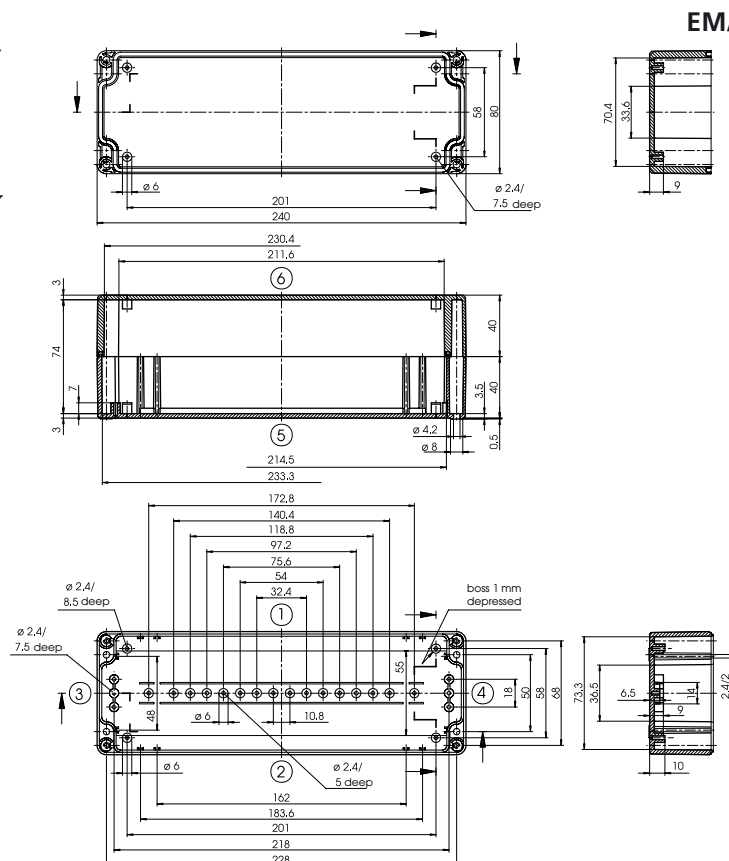
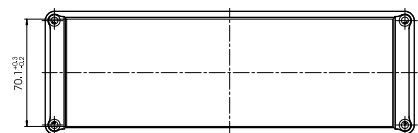
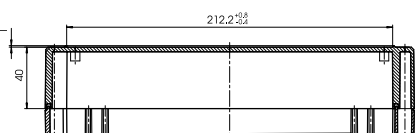

EM/ET 236 (F) LP

Z-2501002

Euromas II

EM/ET 237 (F)

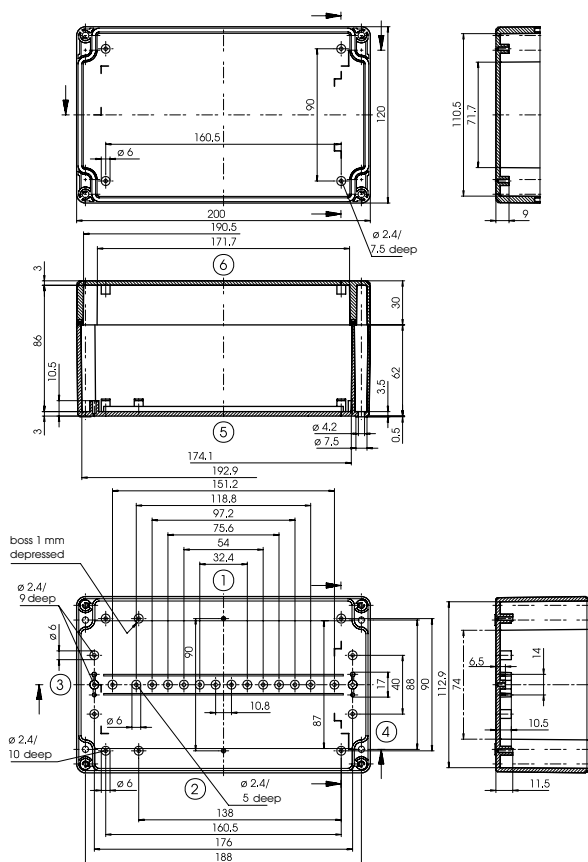

Z-2501006

Order designation

Model	Material	Order no.
EM 237	PC	62237000
ET 237	ABS	63237000

Model	Material	Order no.
EM 237 F	PC	62237200
ET 237 F	ABS	63237200

(F = with membrane keypad area)

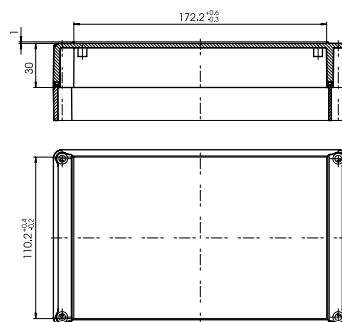

EM/ET 238 (F)

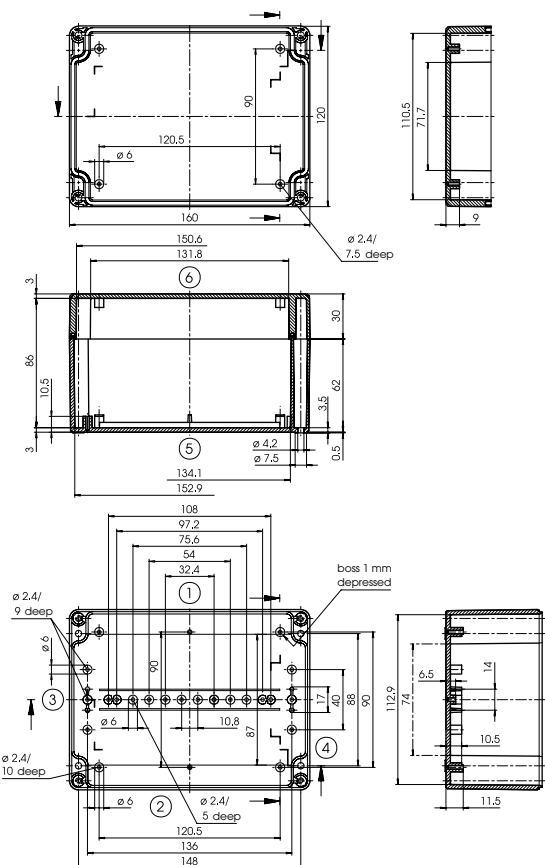

Z-2501005

Order designation

Model	Material	Order no.
EM 238	PC	62238000
ET 238	ABS	63238000

Model	Material	Order no.
EM 238 F	PC	62238200
ET 238 F	ABS	63238200

(F = with membrane keypad area)

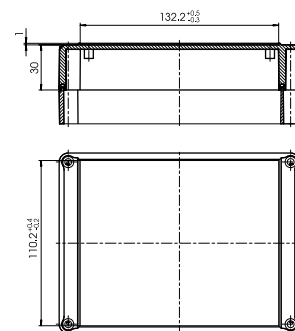

Order designation

Model	Material	Order no.	▶
EM 239	PC	62239000	
ET 239	ABS	63239000	

Model	Material	Order no.	▼
EM 239 F	PC	62239200	
ET 239 F	ABS	63239200	

(F = with membrane keypad area)

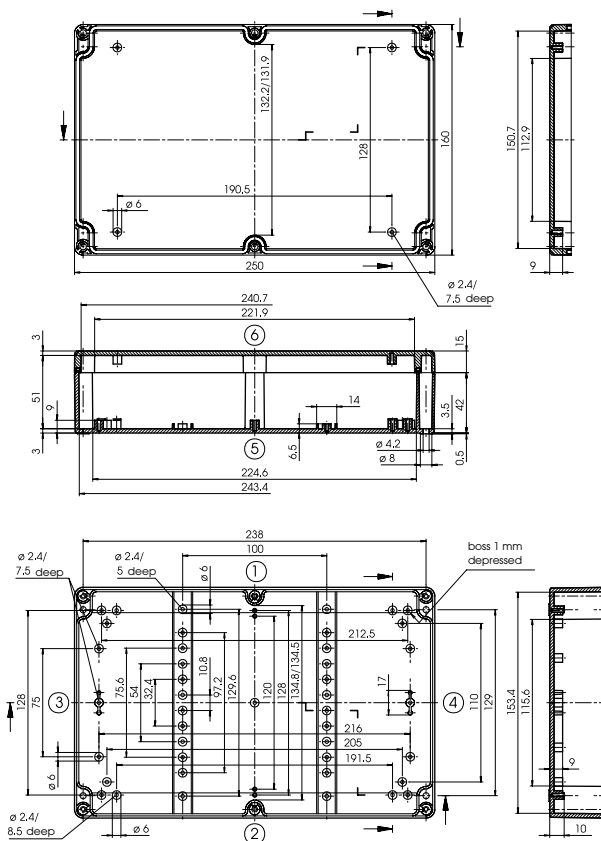
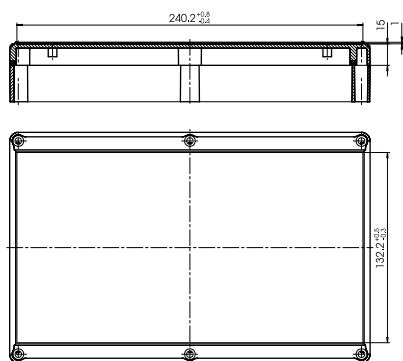

EM/ET 239 (F)

Z-2501037

Order designation

Model	Material	Order no.	▶
EM 240	PC	62240000	
ET 240	ABS	63240000	

Model	Material	Order no.	▼
EM 240 F	PC	62240200	
ET 240 F	ABS	63240200	

(F = with membrane keypad area)

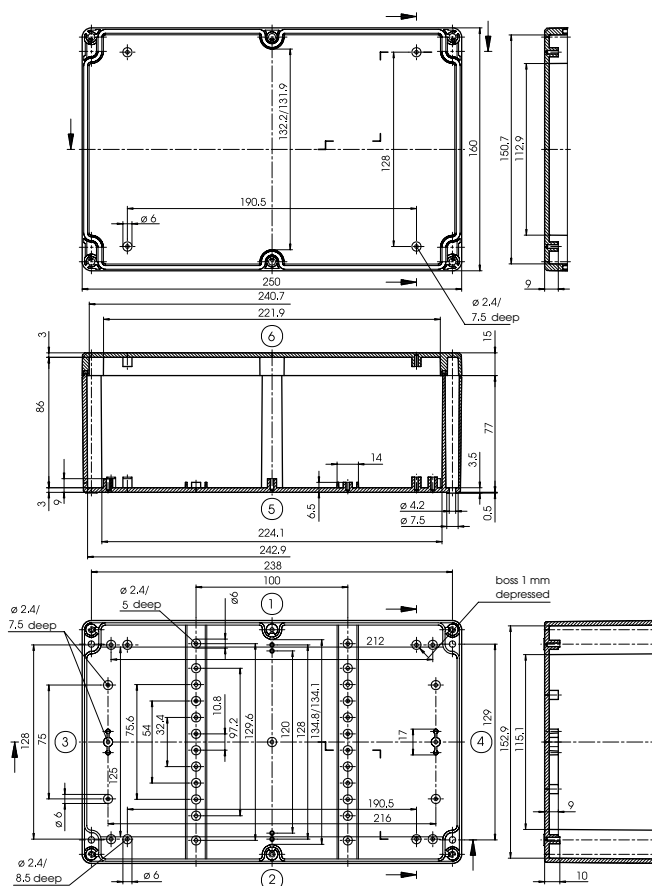
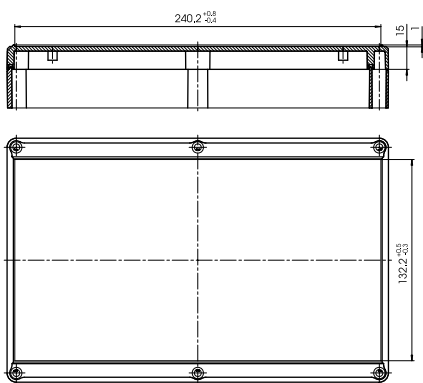

EM/ET 240 (F)

Z-2501003

Euromas II

EM/ET 241 (F)

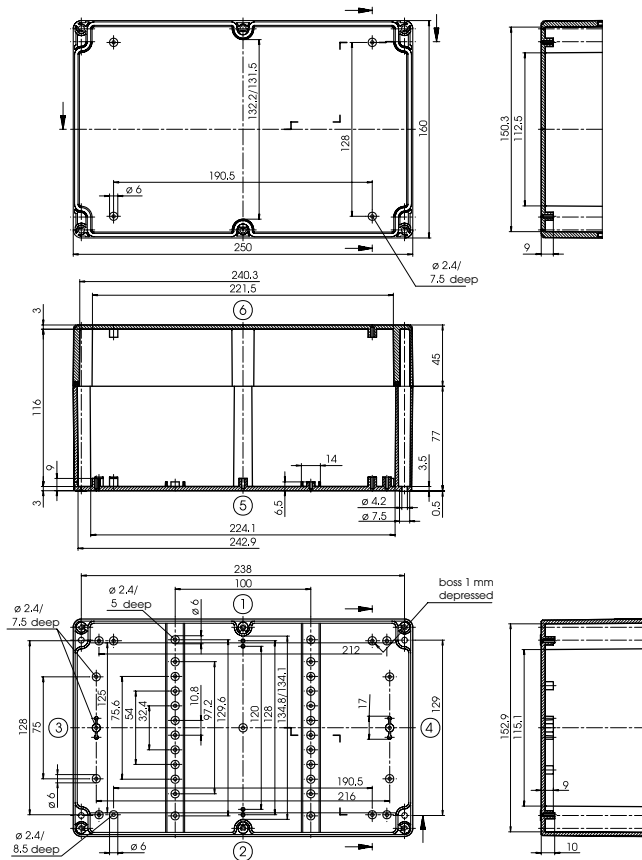

Order designation

Model	Material	Order no.
EM 241	PC	62241000
ET 241	ABS	63241000

Model	Material	Order no.
EM 241 F	PC	62241200
ET 241 F	ABS	63241200

(F = with membrane keypad area)

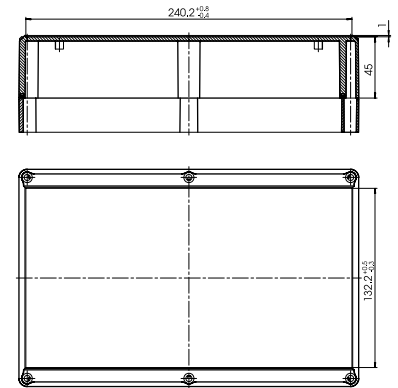

Z-2501004

EM/ET 242 (F)

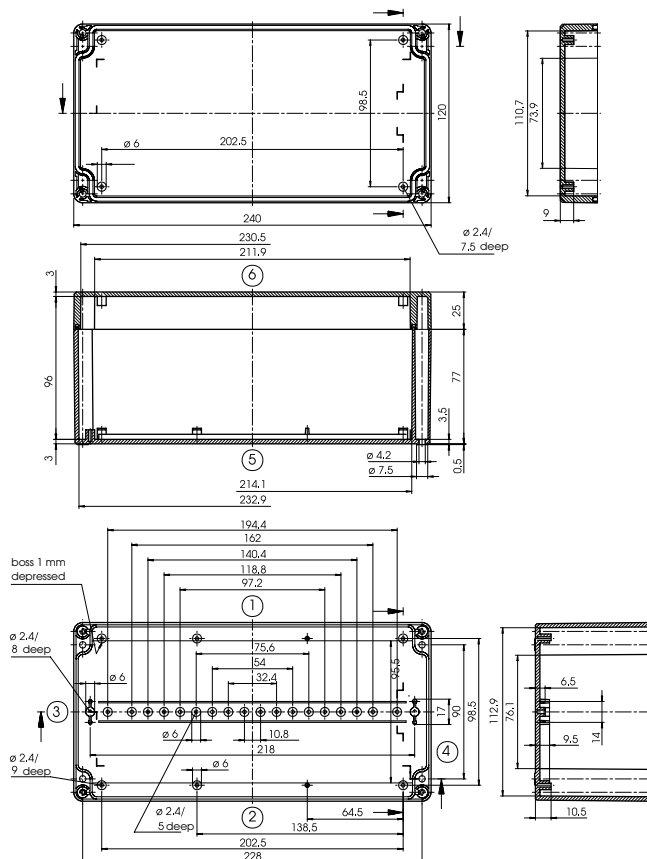

Order designation

Model	Material	Order no.
EM 242	PC	62242000
ET 242	ABS	63242000

Model	Material	Order no.
EM 242 F	PC	62242200
ET 242 F	ABS	63242200

(F = with membrane keypad area)

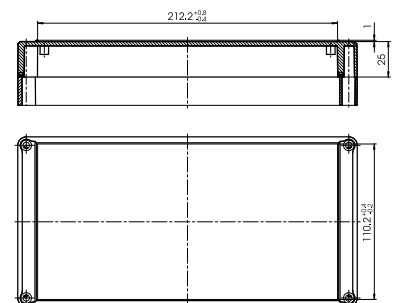

Z-2501139

Order designation

Model	Material	Order no.	▶
EM 247 LP	PC	62247300	
ET 247 LP	ABS	63247300	

Model	Material	Order no.	▼
EM 247 F-LP	PC	62247400	
ET 247 F-LP	ABS	63247400	

(F = with membrane keypad area,
LP = with PCB slots)

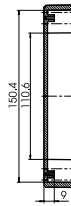
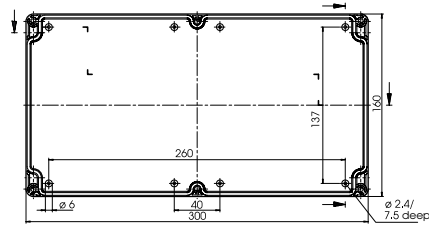

EM/ET 247 (F) LP

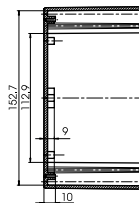
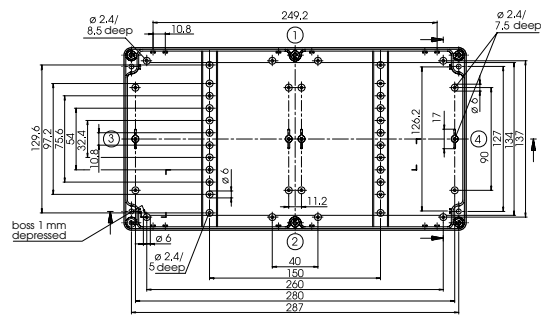
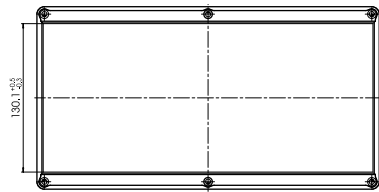
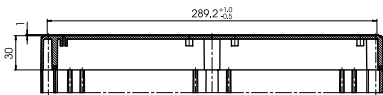
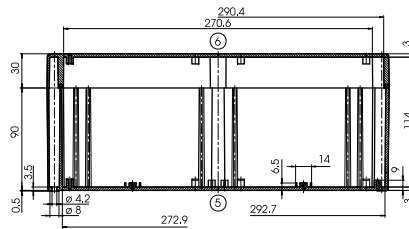

Z-2500991



Euromas II accessories



Self-adhesive rubber feet

Model	Order no.
EM-GF	22009000

Scope of delivery: 1 set = 4 pcs

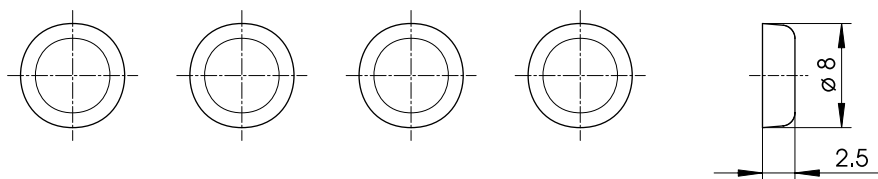

Z-2501779



Screw covers

Model	Order no.	Material
EM-SA	22080000	PC

Scope of delivery: 1 set = 6 pcs

Wall brackets

Model	Order no.	Material
EM-WL	22010000	PC

Scope of delivery: 1 set = 4 pcs

Fitting dimensions

Model	A	B	C	D
EM/ET 210	96	70	68	94
EM/ET 212	114	88	88	114
EM/ET 213	136	110	108	134
EM/ET 214	214	188	108	134
EM/ET 215	134	108	68	94
EM/ET 217	136	110	108	134
EM/ET 218	164	138	138	164
EM/ET 220	174	148	68	94
EM/ET 221	214	188	108	134
EM/ET 223	214	188	138	164
EM/ET 224	254	228	68	94
EM/ET 225	96	70	68	94
EM/ET 227	136	110	108	134
EM/ET 229	174	148	68	94
EM/ET 231	174	148	68	94
EM/ET 232	214	188	138	164
EM/ET 233	264	238	148	174
EM/ET 236	254	228	68	94
EM/ET 237	214	188	108	134
EM/ET 238	174	148	108	134
EM/ET 239	264	238	148	174
EM/ET 240	264	238	148	174
EM/ET 241	264	238	148	174
EM/ET 242	254	228	108	134
EM/ET 247	313	287	147	173

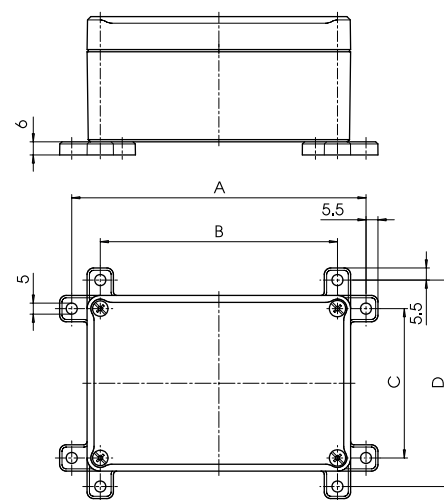



Welcome to BOPLA City!

Euromas II accessories

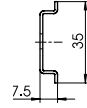
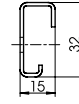
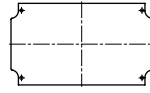

M: Mounting plates,
laminated paper (Pertinax)
TS 15: Top hat rail DIN EN 60715 TH15
TS 32: G-rail DIN EN 60715 G 32
TS 35: Top hat rail DIN EN 60715 TH35

* can also be fitted in lid

Model	M	TS 15	TS 32	TS 35
205	22000100	-	-	-
206	22000200	22150501	-	-
207	22207001*	22150701	-	-
208	-	22150701	22320701	22350701
210	22000300	22150701	22320701	22350701
212	22212000*	22150901	22320901	22350901
213	-	22151101	22321101	22351101
214	22214001*	22151901	22321901	22351901
215	22000400	22151101	22321101	22351101
217	22000500	22151101	22321101	22351101
218	22218001*	22151401	22321401	22351401
220	22000600	22151501	22321501	22351501
221	22000700	22151901	22321901	22351901
223	22000800	22151901	22321901	22351901
224	22224001*	22152301	22322301	22352301
225	22000300	22150701	22320701	22350701
227	22000500	22151101	22321101	22351101
229	-	22151501	22321501	22351501
231	22000600	22151501	22321501	22351501
232	-	22151901	22321901	22351901
233	-	22152301	22322301	22352301
236	22224001*	22152301	22322301	22352301
237	22000700	22151901	22321901	22351901
238	22001100	22151501	22321501	22351501
239	22000900	22152301	22322301	22352301
240	22000900	22152301	22322301	22352301
241	22000900	22152301	22322301	22352301
242	22001200	22152301	22322301	22352301
247	22247001*	22152901	22322901	22352901

For fitting screws for mounting plate and DIN-rail, please refer to page 642 ff.

**Maximum assignment
with terminal blocks**

	Phoenix						Weidmüller				
	MBK 2.5	MBK 3	MBK 5	UK 3 N	UK 5 N	UK 10 N	AKZ 1.5	AKZ 2.5	AKZ 4	SAK 2.5	SAK 4
DIN-rail TS 15	X	X	X				X	X	X		
DIN-rail TS 32				X	X	X				X	X
DIN-rail TS 35				X	X	X					
Bridgeable		X	X	X	X	X	X	X	X	X	X
End angle-piece	2	2	2	2	2	2	2	2	2	2	2
Closing plate	-	1	1	1	1	1	1	1	1	1	1
Connection cross-section (mm ²) fine-strand	1.5	2.5	4	2.5	4	10	1.5	2.5	4	2.5	4
Connection cross-section (mm ²) single wire	2.5	4	4	4	6	16	2.5	4	6	4	10
Nominal voltage (V)	500	500	500	750	750	800	400	250	500	800	800
Rating (A)	26	32	34	34	34	76	17.5	24	32	24	32
Terminal width (mm)	5.2	5.2	6.2	5.2	6.2	10.2	5	5	6	6	6.5

Model	Number per DIN-rail						Number per DIN-rail				
EM/ET 205 (F)	1 x KL16/4 PA-DS terminal block						1 x KL16/4 PA-DS terminal block				
EM/ET 206 (F)	1 x KL16/8 PA-DS terminal block						1 x KL16/8 PA-DS terminal block				
EM/ET 207 LP	7	7	6				7	7	6		
EM/ET 208 (F)	7						7				
EM/ET 210 (F)	7	7	5				7	7	6		
EM/ET 212 (F)	11	11	9				11	11	9		
EM/ET 214 LP	30	30	24				30	30	24		
EM/ET 215 (F)	14	14	11				14	14	11		
EM/ET 217 (F)	15	15	12				15	15	12		
EM/ET 218 LP	20	20	16				20	20	16		
EM/ET 220 (F)	22	22	18				22	22	18		
EM/ET 221 (F) LP	30	30	24	29	23	15	30	30	25	24	23
EM/ET 223 (F)	30	30	24	29	23	15	30	30	25	24	23
EM/ET 224 LP	38	38	30				38	38	30		
EM/ET 225 (F)	7	7	5	6	5	3	7	7	6	6	4
EM/ET 227 (F)	15	15	12	14	11	7	15	15	12	12	11
EM/ET 231 (F)	22	22	18	21	18	11	22	22	18	18	17
EM/ET 236 LP	38	38	30	36	30	20	38	38	30	30	29
EM/ET 237 (F)	30	30	24	29	23	15	30	30	25	23	22
EM/ET 238 (F)	22	22	18	21	18	11	22	22	18	18	17
EM/ET 239 (F)	38	38	30				38	38	31		
EM/ET 240 (F)	38	38	30	36	30	20	38	38	31	30	30
EM/ET 241 (F)	38	38	30	36	30	20	38	38	31	30	30
EM/ET 242 (F)	38	38	30	36	30	20	38	38	31	30	30
EM/ET 247 LP	48	48	40	46	40	24	49	49	41	40	38



The 36 different designs for this DIN IEC 61554 control panel mounting enclosure mean that the user always has the right size for his electronic components. Spring or screw clamps permit fitting in the control panel or switch cabinet to meet your exact requirements.

The clear PVC front covers (available as accessories) protect the front elements up to ingress protection category IP 65.

Enclosure material: Flame resistant noryle SE 1 GFN1.
For technical data see pages 646-651.

Colour: Black, similar to RAL 9005.

Scope of delivery: For NGS: enclosure, standard front frame, rear lid, screws.
For NGS 9806-GR: enclosure, standard front frame, 2 clamping elements.

Accessories (additional charge):

NGS...NF: Spring clamp
 NGS...NK: Screw clamp
 NGS...ZE: Connecting piece for insertion of NGS-NH
 NGS...NH: Standard retaining clasp acc. to DIN 43835 form B
 NGS...FKT: Plastic front panel, red translucent, 3 mm thick
 NGS...FAE: Aluminium front panel, anodized, 1.5 mm thick
 NGS...F: Membrane front, firmly latching
 NGS...TK: NGS front door lockable by means of knob for models 74.., 96.. and 98..
 SHLO-302: Cylinder lock catch for NGS front door

NGS...SA: Open front frame with screw covers, firmly latching
 NGS...AH: Clear hood cover, snap-on for NGS...F/SA
 NGS...DA: Seal enclosure collar – mounting space
 NGS...DI: Seal enclosure – front panel
 NGS...GHN: Flexible transparent PVC hoods for IP 65 front seal
 NGS...RKS: Standard NGS rear wall, separate (included in scope of delivery)

Enclosures		Size in mm		
Model	Order no.	W	H	D
NGS 4806	17480601	48.0	48	63.0
NGS 4808	17480801	48.0	48	85.0
NGS 4810	17481001	48.0	48	109.5
NGS 4811	17481101	48.0	48	119.0
NGS 4813	17481301	48.0	48	141.0
NGS 7406	17740601	144.0	72	64.0
NGS 7408	17740801	144.0	72	86.0
NGS 7410	17741001	144.0	72	110.5
NGS 7411	17741101	144.0	72	120.0
NGS 7413	17741301	144.0	72	142.0
NGS 7416	17741601	144.0	72	166.5
NGS 7706	17770601	72.0	72	63.0
NGS 7708	17770801	72.0	72	85.0
NGS 7710	17771001	72.0	72	109.5
NGS 7711	17771101	72.0	72	119.0
NGS 7713	17771301	72.0	72	141.0
NGS 7716	17771601	72.0	72	165.5
NGS 9406	17940601	96.0	48	63.0
NGS 9408	17940801	96.0	48	85.0
NGS 9410	17941001	96.0	48	109.5
NGS 9411	17941101	96.0	48	119.0
NGS 9413	17941301	96.0	48	141.0
NGS 9416	17941601	96.0	48	165.5
NGS 9606	17960601	96.0	96	63.0
NGS 9608	17960801	96.0	96	85.0
NGS 9610	17961001	96.0	96	109.5
NGS 9611	17961101	96.0	96	119.0
NGS 9613	17961301	96.0	96	141.0
NGS 9616	17961601	96.0	96	165.5
NGS 9806	17980601	144.0	144	64.0
NGS 9808	17980801	144.0	144	86.0
NGS 9810	17981001	144.0	144	110.5
NGS 9811	17981101	144.0	144	120.0
NGS 9813	17981301	144.0	144	142.0
NGS 9816	17981601	144.0	144	166.5
NGS 9806-GR	17980605	144.0	144	68.0

Uninorm



NGS 48

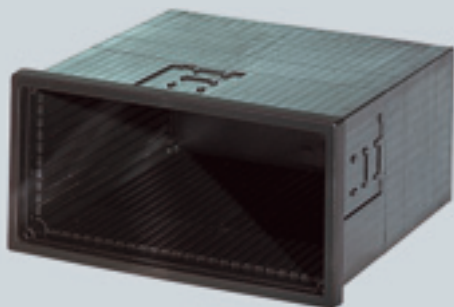

NGS 74

NGS 48

Order designation		External dimensions in mm			
Model	Order no.	W	H	D	E
NGS 4806	17480601	48	48	63.0	56.5
NGS 4808	17480801	48	48	85.0	78.5
NGS 4810	17481001	48	48	109.5	103.0
NGS 4811	17481101	48	48	119.0	112.5
NGS 4813	17481301	48	48	141.0	134.5

Accessories (additional charge)

Model	Order no.
NGS 48 FAE = Front panel, anod. aluminium, 1.5 mm thick	3700050
NGS 48 FKT = Front panel, plastic, red translucent, 3 mm thick	37000610
NGS 48 RKS = Rear wall, separate (included in scope of delivery)	37040100
NGS-NK = Screw clamp (PU = 2 pcs)	37003000
NGS-NF = Spring clamp (PU = 2 pcs)	37005000
NGS-ZE = Connecting piece for DIN retaining clasp (PU = 2 pcs)	37004000
NGS-NH = DIN retaining clasp (PU = 2 pcs)	37001000
NGS 48 DA = Seal, enclosure/control panel (PU = 5 pcs)	37048000
NGS 48 DI = Seal, front panel/enclosure (PU = 5 pcs)	37048010
NGS 48 F = Firmly latching membrane front	37948500
NGS 48 SA = Front frame, firmly latching	37948600
NGS 48 AH* = Clear hood cover	37948700
NGS 48 GHN = Flexible transparent PVC hood	37004800

For descriptions and illustrations of accessories, see pages 362-365.

* available on request

NGS 74

Order designation		External dimensions in mm			
Model	Order no.	W	H	D	E
NGS 7406	17740601	72	144	64.0	56.0
NGS 7408	17740801	72	144	86.0	78.5
NGS 7410	17741001	72	144	110.5	103.0
NGS 7411	17741101	72	144	120.0	112.5
NGS 7413	17741301	72	144	142.0	134.5
NGS 7416	17741601	72	144	166.5	159.0

Accessories (additional charge)

Model	Order no.
NGS 74 FAE = Front panel, anod. aluminium, 1.5 mm thick	37000200
NGS 74 FKT = Front panel, plastic, red translucent, 3 mm thick	37000700
NGS 74 RKS = Rear wall, separate (included in scope of delivery)	37001620
NGS-NK = Screw clamp (PU = 2 pcs)	37003000
NGS-NF = Spring clamp (PU = 2 pcs)	37005000
NGS-ZE = Connecting piece for DIN retaining clasp (PU = 2 pcs)	37004000
NGS-NH = DIN retaining clasp (PU = 2 pcs)	37001000
NGS 74 DA = Seal, enclosure/control panel (PU = 5 pcs)	37074000
NGS 74 DI = Seal, front panel/enclosure (PU = 5 pcs)	37074010
NGS 74 F = Firmly latching membrane front	37974500
NGS 74 SA = Front frame, firmly latching	37974600
NGS 74 AH* = Clear hood cover	37974700
NGS 74 GHN = Flexible transparent PVC hood	37007400
NGS 74 TK = Front door lockable by means of knob	17740000
SHLO-302 = Cylinder catch for front door	21008310

For descriptions and illustrations of accessories, see pages 362-365.

* available on request

Cut-out to DIN IEC 61554
 $45^{+0,6} \times 45^{+0,6}$

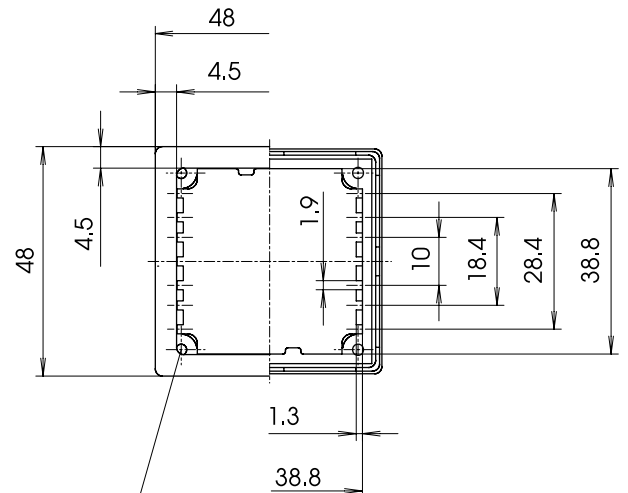
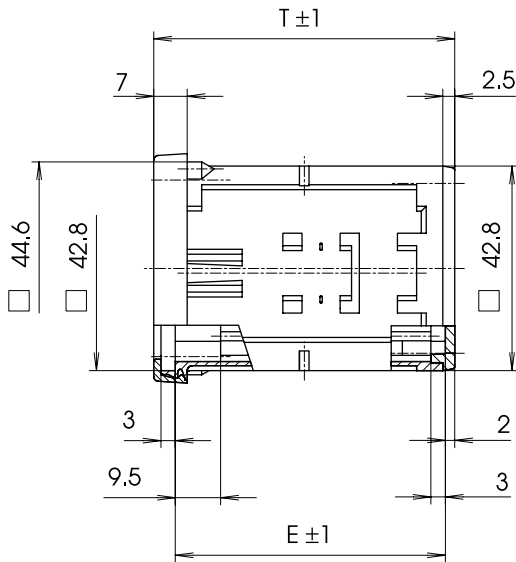

front panel
 fixing points
 37 mm x 37 mm

Z-2600825

Cut-out to DIN IEC 61554
 $68^{+0,7} \times 138^{+1,0}$

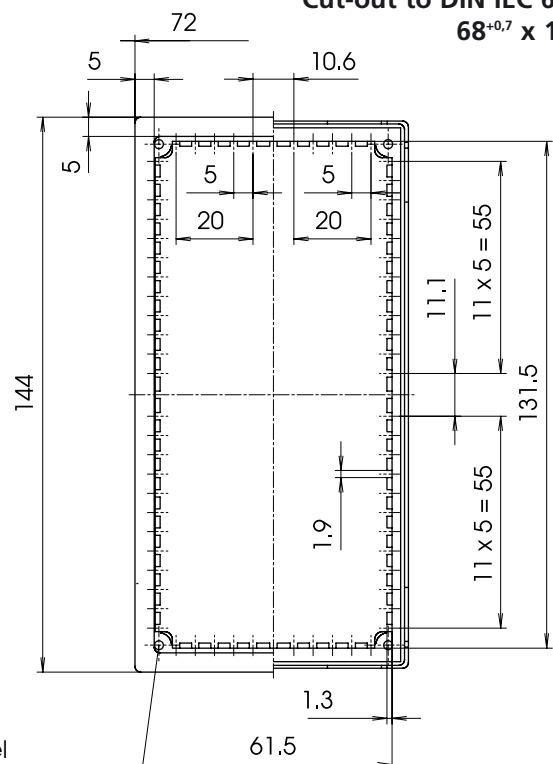
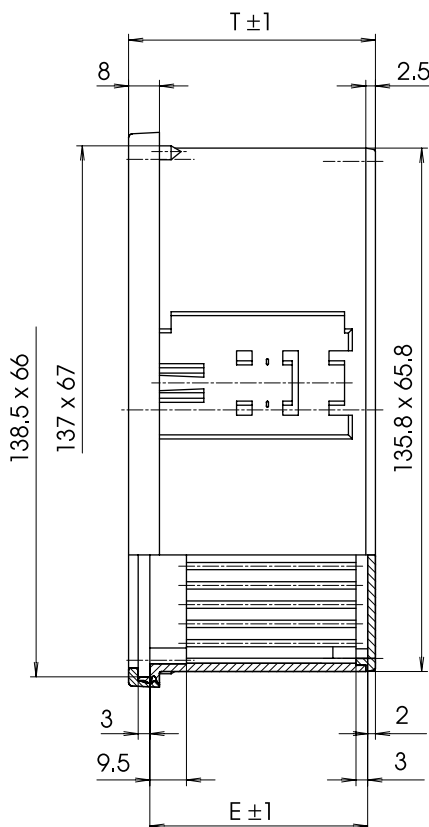

front panel
 fixing points
 59.5 mm x 130 mm

Z-2600827

Uninorm



NGS 77

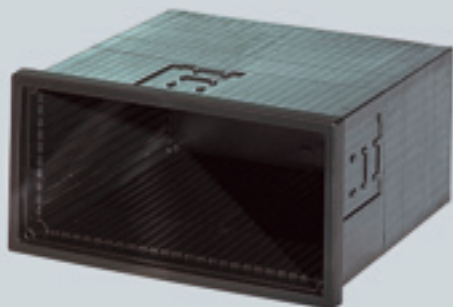

NGS 94

NGS 77

Order designation		External dimensions in mm			
Model	Order no.	W	H	D	E
NGS 7706	17770601	72	72	63.0	56.5
NGS 7708	17770801	72	72	85.0	78.5
NGS 7710	17771001	72	72	109.5	103.0
NGS 7711	17771101	72	72	119.0	112.5
NGS 7713	17771301	72	72	141.0	134.5
NGS 7716	17771601	72	72	165.5	159.0

Accessories (additional charge)

Model	Order no.
NGS 77 FAE = Front panel, anod. aluminium, 1.5 mm thick	37000100
NGS 77 FKT = Front panel, plastic, red translucent, 3 mm thick	37000600
NGS 77 RKS = Rear wall, separate (included in scope of delivery)	37001610
NGS-NK = Screw clamp (PU = 2 pcs)	37003000
NGS-NF = Spring clamp (PU = 2 pcs)	37005000
NGS-ZE = Connecting piece for DIN retaining clasp (PU = 2 pcs)	37004000
NGS-NH = DIN retaining clasp (PU = 2 pcs)	37001000
NGS 77 DA = Seal, enclosure/control panel (PU = 5 pcs)	37077000
NGS 77 DI = Seal, front panel/enclosure (PU = 5 pcs)	37077010
NGS 77 F = Firmly latching membrane front	37977500
NGS 77 SA = Front frame, firmly latching	37977600
NGS 77 AH* = Clear hood cover	37977700
NGS 77 GHN = Flexible transparent PVC hood	37007700

For descriptions and illustrations of accessories, see pages 362-365.

* available on request

NGS 94

Order designation		External dimensions in mm			
Model	Order no.	W	H	D	E
NGS 9406	17940601	48	96	63.0	56.5
NGS 9408	17940801	48	96	85.0	78.5
NGS 9410	17941001	48	96	109.5	103.0
NGS 9411	17941101	48	96	119.0	112.5
NGS 9413	17941301	48	96	141.0	134.5
NGS 9416	17941601	48	96	165.5	159.0

Accessories (additional charge)

Model	Order no.
NGS 94 FAE = Front panel, anod. aluminium, 1.5 mm thick	37000300
NGS 94 FKT = Front panel, plastic, red translucent, 3 mm thick	37000800
NGS 94 RKS = Rear wall, separate (included in scope of delivery)	37001600
NGS-NK = Screw clamp (PU = 2 pcs)	37003000
NGS-NF = Spring clamp (PU = 2 pcs)	37005000
NGS-ZE = Connecting piece for DIN retaining clasp (PU = 2 pcs)	37004000
NGS-NH = DIN retaining clasp (PU = 2 pcs)	37001000
NGS 94 DA = Seal, enclosure/control panel (PU = 5 pcs)	37094000
NGS 94 DI = Seal, front panel/enclosure (PU = 5 pcs)	37094010
NGS 94 F = Firmly latching membrane front	37994500
NGS 94 SA = Front frame, firmly latching	37994600
NGS 94 AH* = Clear hood cover	37994700
NGS 94 GHN = Flexible transparent PVC hood	37009400

For descriptions and illustrations of accessories, see pages 362-365.

* available on request

Cut-out to DIN IEC 61554
 $68^{+0,7} \times 68^{+0,7}$

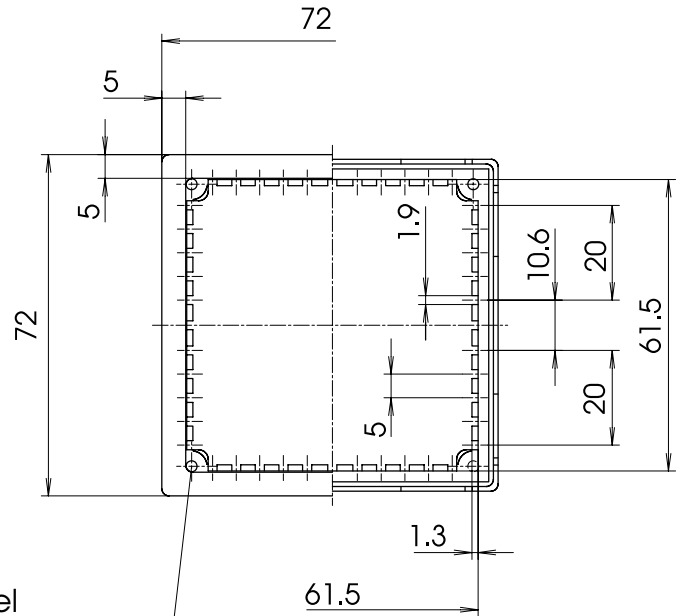
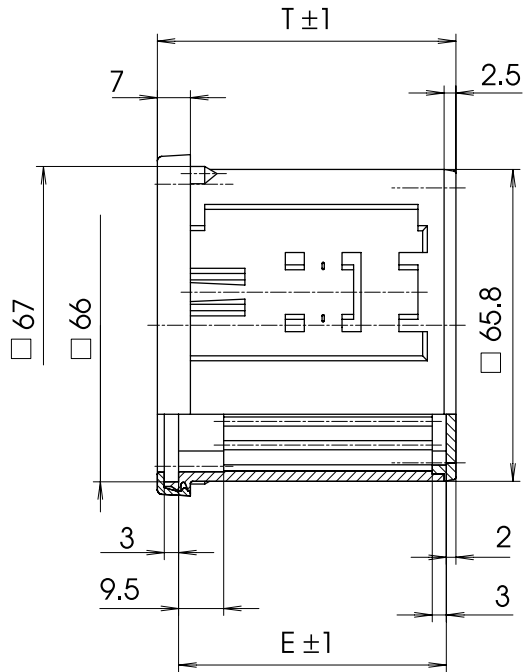

front panel
 fixing points
 59.5 mm x 59.5 mm

Z-2600826

Cut-out to DIN IEC 61554
 $45^{+0,6} \times 92^{+0,8}$

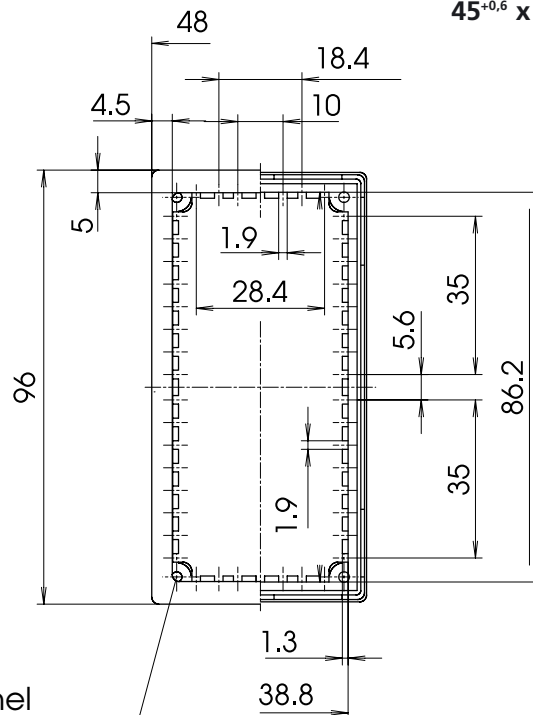
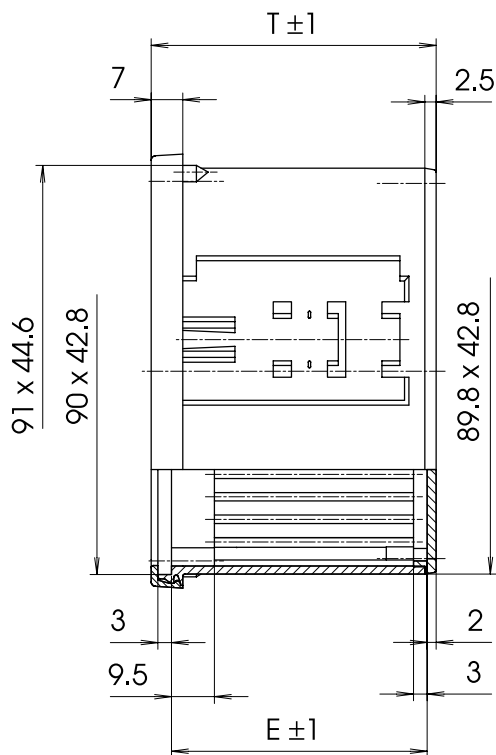

front panel
 fixing points
 37 mm x 84 mm

Z-2600828

Uninorm



NGS 96

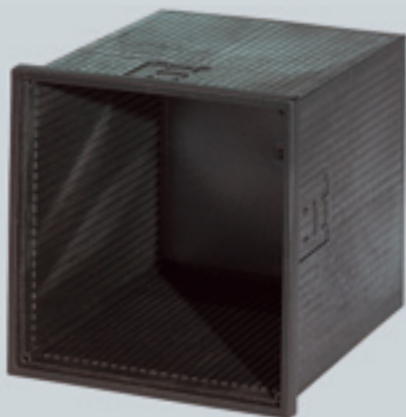

NGS 98

NGS 96

Order designation		External dimensions in mm			
Model	Order no.	W	H	D	E
NGS 9606	17960601	96	96	63.0	56.5
NGS 9608	17960801	96	96	85.0	78.5
NGS 9610	17961001	96	96	109.5	103.0
NGS 9611	17961101	96	96	119.0	112.5
NGS 9613	17961301	96	96	141.0	134.5
NGS 9616	17961601	96	96	165.5	159.0

Accessories (additional charge)

Model	Order no.
NGS 96 FAE = Front panel, anod. aluminium, 1.5 mm thick	37000400
NGS 96 FKT = Front panel, plastic, red translucent, 3 mm thick	37000900
NGS 96 RKS = Rear wall, separate (included in scope of delivery)	37001630
NGS-NK = Screw clamp (PU = 2 pcs)	37003000
NGS-NF = Spring clamp (PU = 2 pcs)	37005000
NGS-ZE = Connecting piece for DIN retaining clasp (PU = 2 pcs)	37004000
NGS-NH = DIN retaining clasp (PU = 2 pcs)	37001000
NGS 96 DA = Seal, enclosure/control panel (PU = 5 pcs)	37096000
NGS 96 DI = Seal, front panel/enclosure (PU = 5 pcs)	37096010
NGS 96 F = Firmly latching membrane front	37996500
NGS 96 SA = Front frame, firmly latching	37996600
NGS 96 AH* = Clear hood cover	37996700
NGS 96 GHN = Flexible transparent PVC hood	37009600
NGS 96 TK = Front door lockable by means of knob	17960000
SHLO-302 = Cylinder catch for front door	21008310

For descriptions and illustrations of accessories, see pages 362-365.

* available on request

NGS 98

Order designation		External dimensions in mm			
Model	Order no.	W	H	D	E
NGS 9806	17980601	144	144	64.0	56.5
NGS 9808	17980801	144	144	85.0	78.5
NGS 9810	17981001	144	144	110.5	103.0
NGS 9811	17981101	144	144	120.0	112.5
NGS 9813	17981301	144	144	142.0	134.5
NGS 9816	17981601	144	144	166.5	159.0

Accessories (additional charge)

Model	Order no.
NGS 98 FAE = Front panel, anod. aluminium, 1.5 mm thick	37000500
NGS 98 FKT = Front panel, plastic, red translucent, 3 mm thick	37000950
NGS 98 RKS = Rear wall, separate (included in scope of delivery)	37001640
NGS-NK = Screw clamp (PU = 2 pcs)	37003000
NGS-NF = Spring clamp (PU = 2 pcs)	37005000
NGS-ZE = Connecting piece for DIN retaining clasp (PU = 2 pcs)	37004000
NGS-NH = DIN retaining clasp (PU = 2 pcs)	37001000
NGS 98 DA = Seal, enclosure/control panel (PU = 5 pcs)	37098000
NGS 98 DI = Seal, front panel/enclosure (PU = 5 pcs)	37098010
NGS 98 F = Firmly latching membrane front	37998500
NGS 98 SA = Front frame, firmly latching	37998600
NGS 98 AH* = Clear hood cover	37998700
NGS 98 GHN = Flexible transparent PVC hood	37009800
NGS 98 TK = Front door lockable by means of knob	17980000
SHLO-302 = Cylinder catch for front door	21008310

For descriptions and illustrations of accessories, see pages 362-365.

* available on request

Cut-out to DIN IEC 61554
 $92^{+0,8} \times 92^{+0,8}$

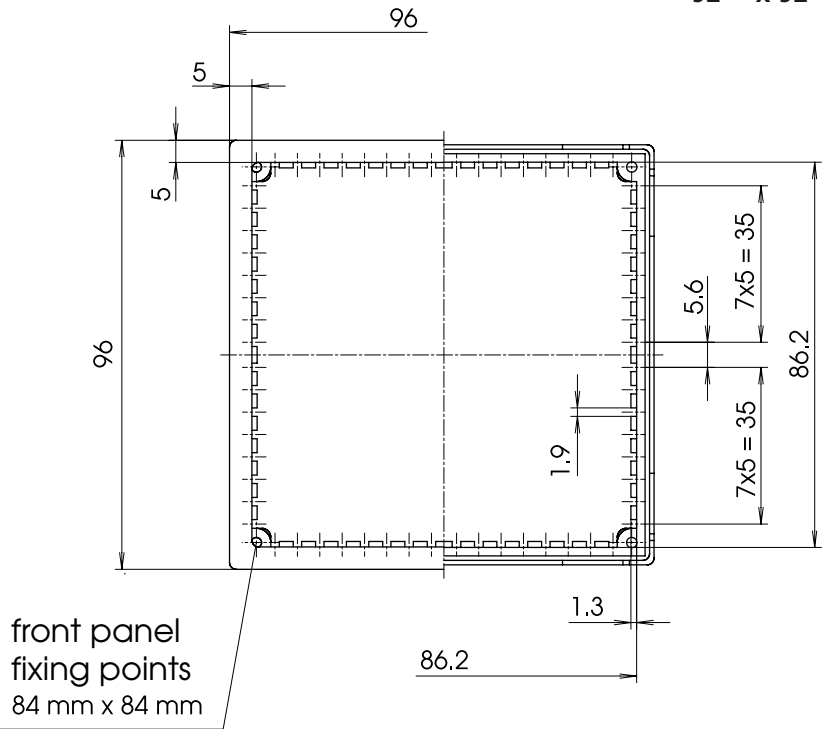
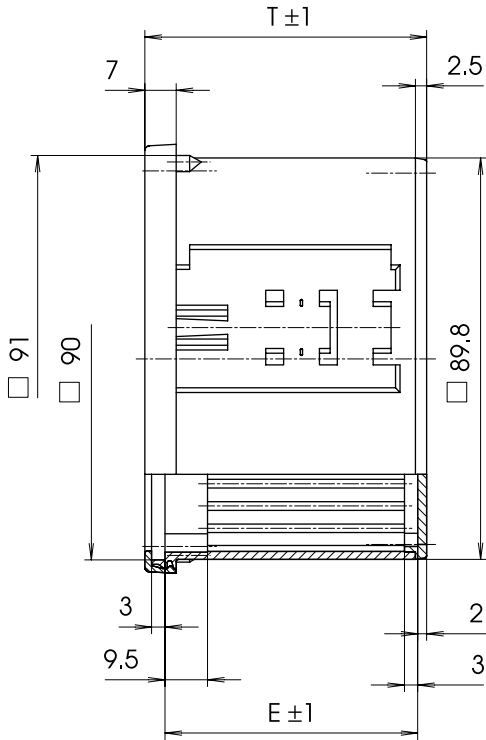

Z-2600829

Cut-out to DIN IEC 61554
 $138^{+1,0} \times 138^{+1,0}$

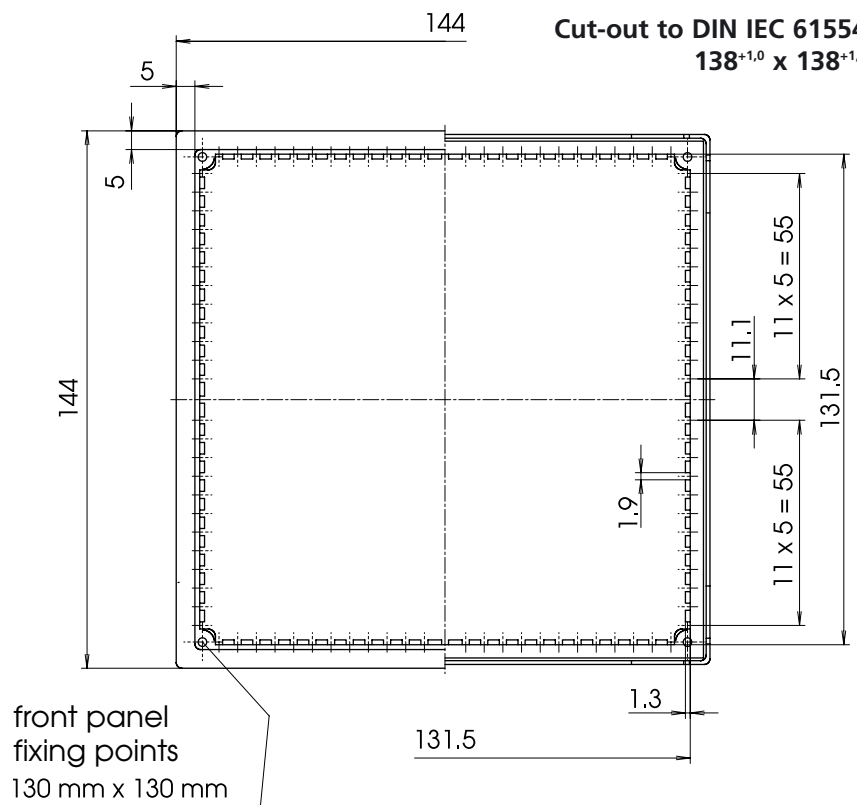
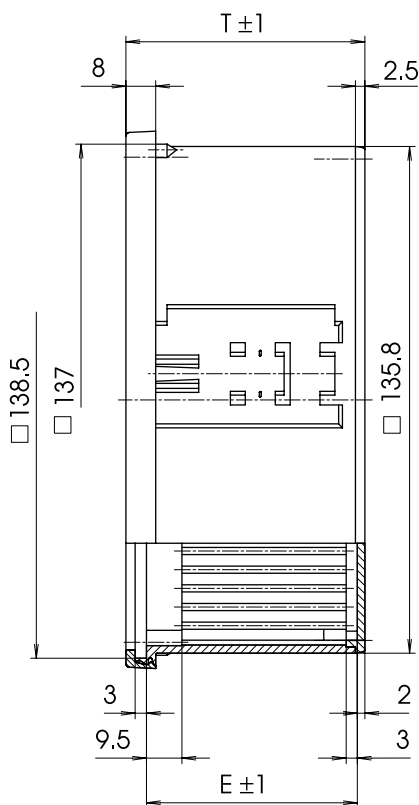

Z-2600830

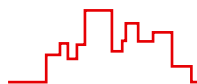

Uninorm

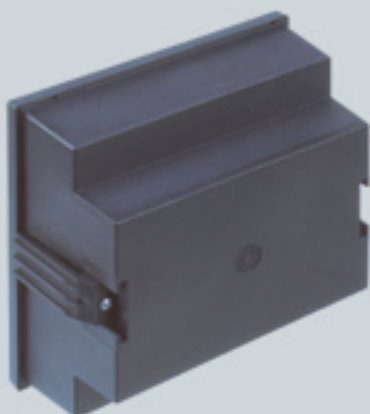

NGS 9806-GR
(with stepped rear panel)

NGS 9806-GR

Order designation		External dimensions in mm		
Model	Order-no.	L	W	H
NGS 9806-GR	17980605	144	144	68

Accessories (additional charge)

Model	Order no.
NGS 98 FAE = Front panel alu-anodized, 3 mm thick	37000510
NGS 98 FKT = Front plate, plastic, red translucent, 3 mm thick	37000950
NGS 98 DI = Seal, front panel/enclosure (PU: 5 pieces)	37098010
NGS 98 F = Firmly-latching membrane front	37998500
NGS 98 SA = Firmly-latching front frame	37998600
NGS 98 AH = Clear hood cover	37998700
NGS 98 GHN = Flexible transparent PVC hood	37009800
NGS 98 TK = Front door, lockable with knob	17980000
SHLO-302 = Cylinder catch for front door	21008310

For descriptions and illustrations of accessories, see pages 362-365.

Cut-out to DIN IEC 61554
138^{+1,0} x 138^{+1,0}

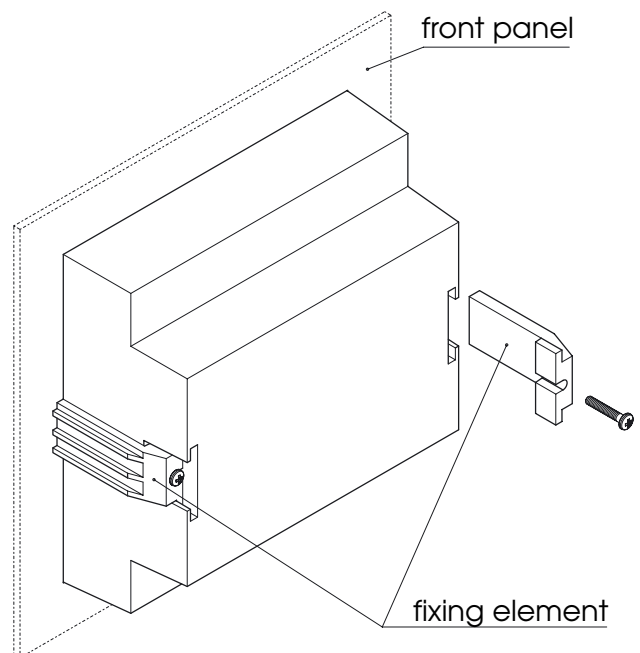
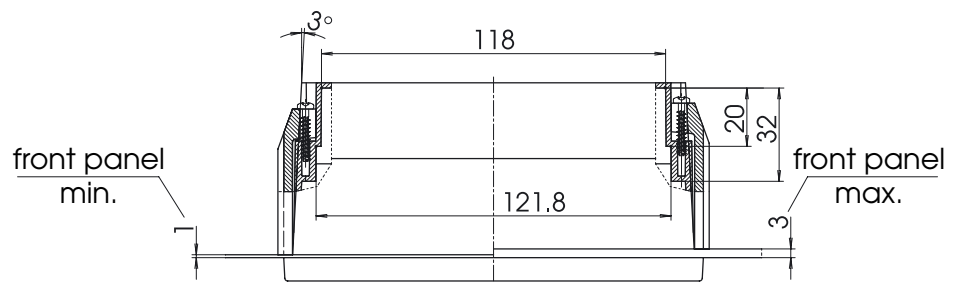
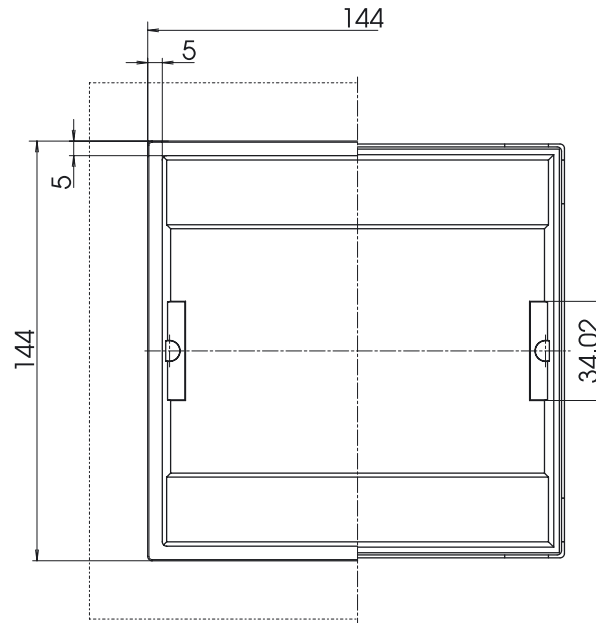
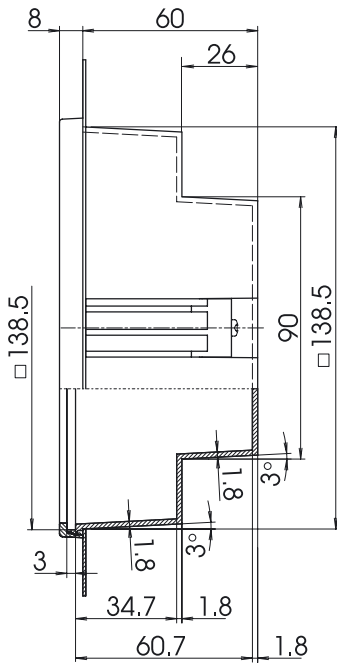



Uninorm accessories

NGS spring clamp

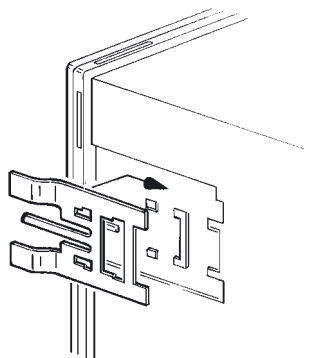

Order designation

Model	Order no.	PU
NGS-NF	37005000	2

The NF spring clamp is snapped onto the external wall of the enclosure and then, with the enclosure, snapped into the control panel cut-out.

NGS screw clamp

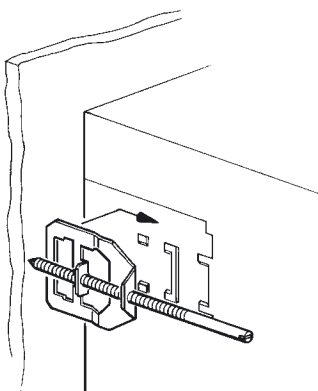

Order designation

Model	Order no.	PU
NGS-NK	37003000	2

The screw clamp is placed on the enclosure from the rear of the control panel. After this, the enclosure is pressed firmly onto the rear wall of the control panel through the integrated screw.

NGS connecting piece

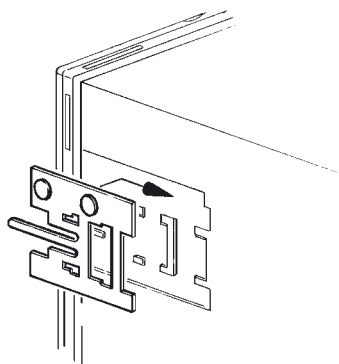

Order designation

Model	Order no.	PU
NGS-ZE	37004000	2

The ZE connecting piece is suitable for use with standard retaining clasps in accordance with DIN 43835.

NGS retaining clasp

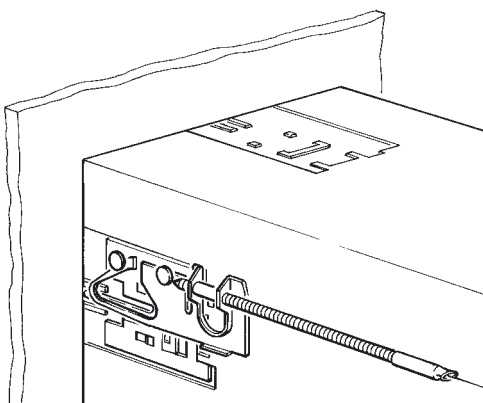

Order designation

Model	Order no.	PU
NGS-NH	37001000	2

Standard retaining clasp in accordance with DIN 43835 form B. Can only be used together with connecting piece NGS-ZE.

This 1.5 mm thick anodized aluminium front panel can be sealed towards the enclosure by means of NGS...DI seals. Take the different panel shapes into account.

NGS front panel, anodized aluminium

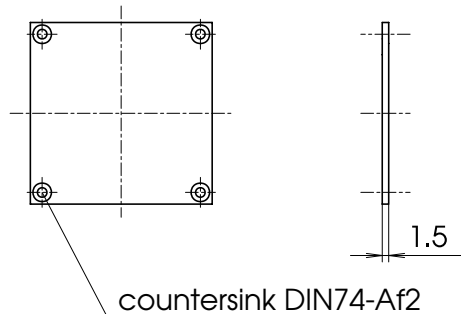

Z-2600851

This 3 mm translucent red plexiglass pane is especially suitable for use with LEDs. Additional sealing is not possible in the case of NGS...DI.

NGS front panel, plastic, red translucent

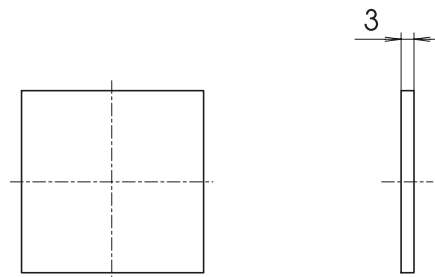

Z-2600851

The NGS..DI (neoprene foam rubber, 1.5 mm thick) can be used to seal the NGS...FAE front panels towards the interior of the enclosure. Take the different panel shapes into account.

NGS seal DI (non-definable protection category)

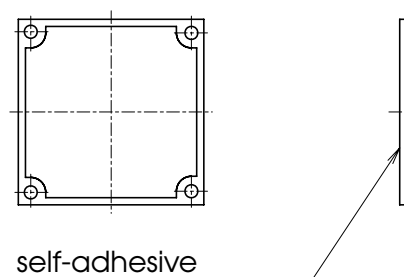

Z-2600851

These seals (neoprene foam rubber, 1.5 mm thick) can be used to seal the enclosure in respect of the control panel wall. Here too, take any different panel shapes into account. If necessary, 4 fixing elements can be used to achieve optimal fitting.

NGS seal DA (non-definable protection category)

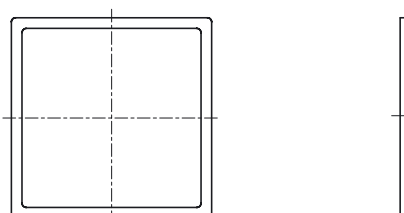

Z-2600851

Uninorm

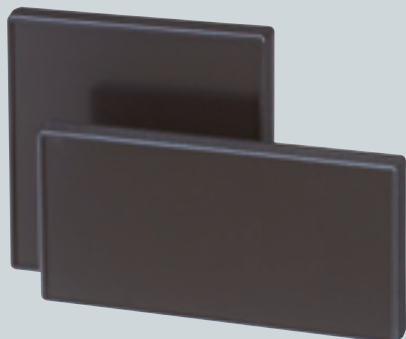

Firmly latching membrane front to accept membrane keypads, etc.

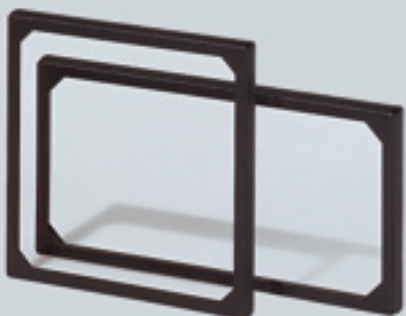

Firmly latching front frame with corner trim to conceal screws.



Clear hood cover for placing on the firmly latching front frame NGS-F/SA. Provides simple, effective protection for operating and display elements.

NGS membrane fronts NGS...F

Order designation

Model	Order no.	B	H	T1	S	B1	H1
NGS 48 F	37948500	48.4	48.4	8	1.5	45.1 ^{+0.2} _{-0.1}	45.1 ^{+0.2} _{-0.1}
NGS 74 F	37974500	72.4	144.4	9	2.5	68.1 ^{+0.3} _{-0.2}	140.1 ^{+0.5} _{-0.3}
NGS 77 F	37977500	72.4	72.4	8	1.5	68.1 ^{+0.3} _{-0.2}	68.1 ^{+0.3} _{-0.2}
NGS 94 F	37994500	48.4	96.4	8	1.5	45.1 ^{+0.2} _{-0.1}	92.1 ^{+0.4} _{-0.2}
NGS 96 F	37996500	96.4	96.4	8	1.5	92.1 ^{+0.4} _{-0.2}	92.1 ^{+0.4} _{-0.2}
NGS 98 F	37998500	144.4	144.4	9	2.5	140.1 ^{+0.5} _{-0.3}	140.1 ^{+0.5} _{-0.3}

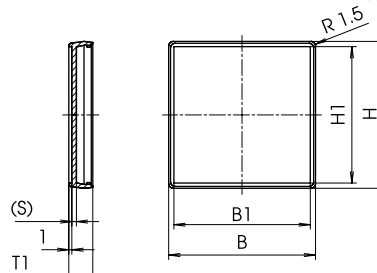

Z-2601268

NGS front frames NGS...SA

Order designation

Model	Order no.	B	H	T1	S	B1	H1	F
NGS 48 SA	37948600	48.4	48.4	7	1.5	39	39	5.40
NGS 74 SA	37974600	72.4	144.4	8	2.5	62	134	6.65
NGS 77 SA	37977600	72.4	72.4	7	1.5	62	62	5.40
NGS 94 SA	37994600	48.4	96.4	7	1.5	38	86	5.40
NGS 96 SA	37996600	96.4	96.4	7	1.5	86	86	5.40
NGS 98 SA	37998600	144.4	144.4	8	2.5	34	134	7.40

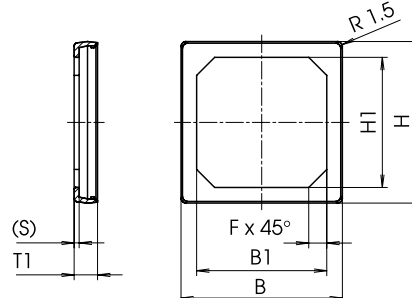

Z-2601268

NGS hood covers

Order designation

Model	Order no.	B	H
NGS 48 AH*	37948700	52.7	52.7
NGS 74 AH*	37974700	76.7	148.7
NGS 77 AH*	37977700	76.7	76.7
NGS 94 AH*	37994700	52.7	100.7
NGS 96 AH*	37996700	100.7	100.7
NGS 98 AH*	37998700	148.7	148.7

* available on request

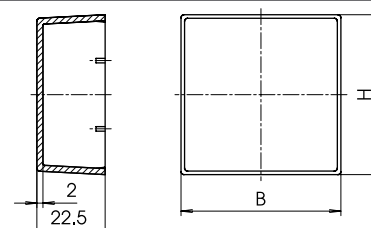

Z-2601268

NGS flexible transparent PVC hoods NGS...GHN

Order designation

Model	Order no.	B	H	T1	B1	H1
NGS 48 GHN	37004800	54	54	8	48.4	48.4
NGS 74 GHN	37007400	78	150	9	72.4	144.4
NGS 77 GHN	37007700	78	78	8	72.4	72.4
NGS 94 GHN	37009400	54	102	8	48.8	96.4
NGS 96 GHN	37009600	102	102	8	96.4	96.4
NGS 98 GHN	37009800	150	150	9	144.4	144.4

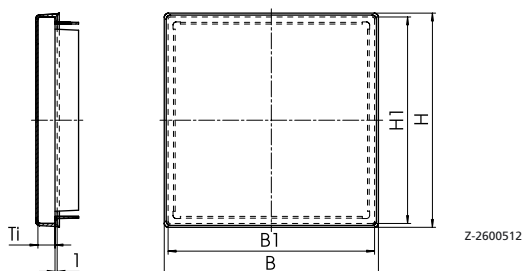

Flexible transparent PVC hoods for DIN IEC 61554 insertion enclosures. Buttons or rocker switches can be operated through the hood. Protection category up to IP 65, depending on assembly.

NGS front doors NGS...TK

Order designation

Model	Order no.
NGS 74 TK	17740000
NGS 96 TK	17960000
NGS 98 TK	17980000

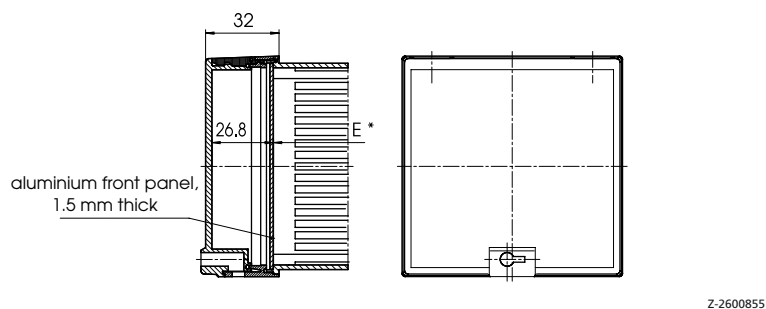

Front door lockable by means of knob

NGS cylinder catch for front door

Order designation

Model	Order no.
SHLO-302	21008310



Cylinder catch for front door