

The striking design and large number of horizontal and vertical insertion slots for PCBs distinguish InterCard markedly from comparable enclosure systems. The hinge system which is integrated in the side walls means that you can choose which way the door opens.

The wall fitting (three- or four-point fixing) is outside the sealed lip, so it does not affect the ingress protection category IP 65.

The terminal compartment cover locks in the open position. This makes it especially easy to carry out wiring operations in this section.

Enclosure material: ABS, clear polycarbonate lid.
For technical data see pages 646-651.

Colour: Light grey, similar to RAL 7035.
Special colours and min. order quantities on request.

Ingress protection: IP 65/DIN EN 60529

Accessories (additional charge):

MP 5000: Mounting plate
FA 5000: Front panel, anodized
SHLO-302: Cylinder catch

Scope of delivery:
Base; hinged clear lid, mounted with snap lock; terminal compartment cover; screws; threaded inserts for mounting plates.

Order designation

Model	Order no.	Designation
IC 5000	07500000	InterCard enclosure

Accessories (add. charge)	Order no.	Designation / Scope of delivery
SHLO-302	21008310	Cylinder catch
MP 5000	27450000	Mounting plate, fixing screws
FA 5000	27350000	Front panel, fixing screws

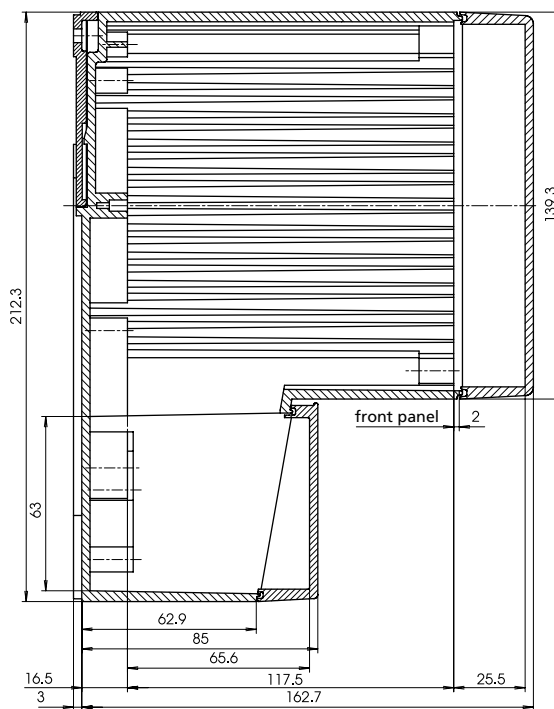
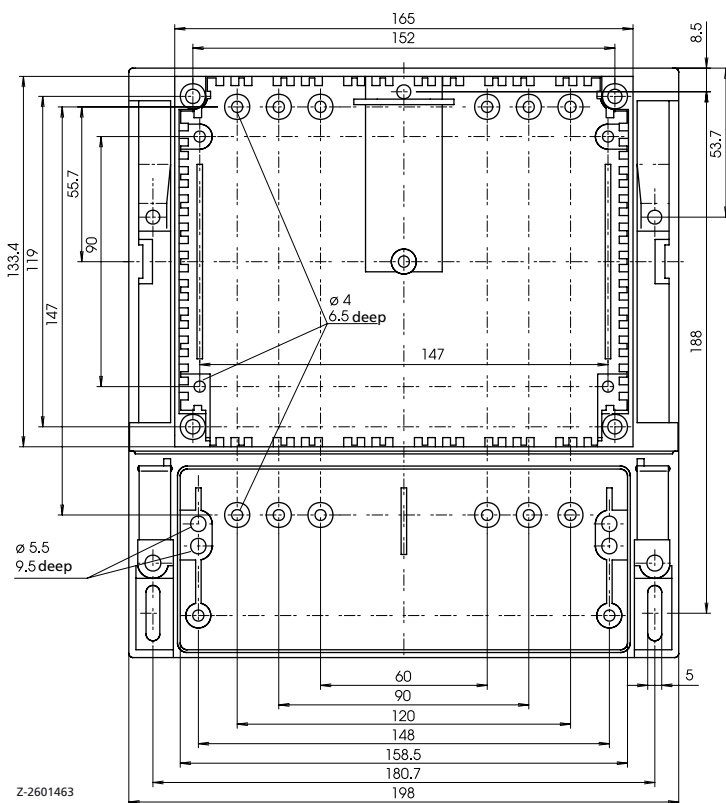

Mounting plate, laminated paper, 2 mm thick

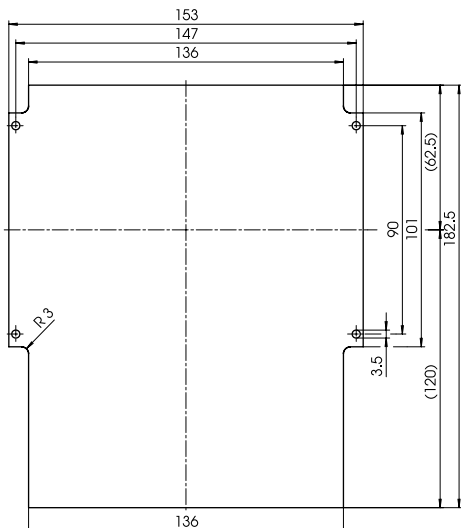

Front panel, anodized aluminium, 2 mm thick

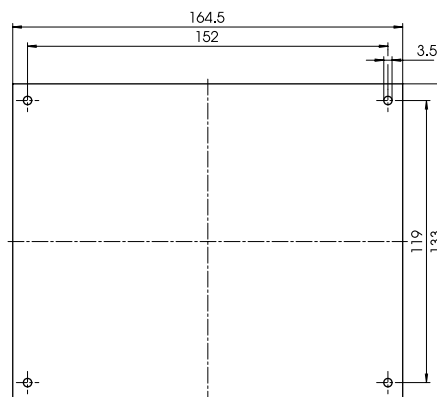

Z-2600767

Z-2600650